



Installation, Operation and Maintenance Information

Type EMH-T/EMV-T Boiler Feed Pumps

Caution: This unit is designed for atmospheric operation. DO NOT pressurize Receiver.

SITE INSPECTION

The unit should be of the proper size and capacity for the proposed installation. Refer to nameplate for rated capacities. Check motor and control voltages with the available power supply.

UNIT LOCATION

Units are designed with O.D.P. (Open Drip Proof) Motors and Nema I controls. Locate unit only in areas of the proper classification. The unit should be located to allow for removal of pumps for replacement of seals.

VENT CONNECTION

Install a full sized vent to atmosphere from the receiver. DO NOT install any shut-off valves or other type of valves in the vent line. Do not plug vent to test system for leaks. Receiver is not made to be pressurized.



OVERFLOW

Install overflow piping to drain. (An overflow loop and antisiphoning orifice can be installed to prevent venting through the overflow.)

WATER MAKE-UP

Provide a water supply to the water make-up valve.

RETURN PIPING

Properly pitched gravity return lines are piped to the unit as shown in the Typical Piping Diagram (Figure 2). An isolation valve should be installed for servicing. An inlet strainer should be installed to remove foreign material and prolong the pump life.

DISCHARGE PIPING

Install a union immediately beyond the pump discharge. A check valve should be installed in the discharge piping close to the pump to prevent back flow into the unit. A pressure relief valve should be installed in the discharge piping to prevent overloading the motor should a pressure increase occur.

ELECTRICAL WIRING

Units are furnished for most popular voltages. Make sure the motor wiring, starters, transformers, etc., match the power supply. Controls, starter coils, etc., should match the control voltages. The control circuit is the secondary side of transformers when furnished.

Single phase motors are usually furnished as dual voltage 115/230v/1/60. Motors should be connected according to manufacturer's instructions for correct voltage.

Three phase motors are usually furnished as tri-voltage 208/230/460/3/60. Motors should be connected according to manufacturer's instructions for correct voltage.

Control panels furnished with the unit should have the nameplate data match the supply current. Should the nameplate data not match the power supply, consult factory.

Wire in accordance with the National Electrical Code and Local Codes where applicable.

Single phase drip proof motors up to and including 1 HP have built-in thermal overload protection. Magnetic starters are not required on these motors.

Single phase drip proof motors larger than 1 HP and all three phase motors require magnetic starters.

SHORT CIRCUIT PROTECTION

According to the National Electrical Code, branch circuit overcurrent protection must be provided for each contactor or starter. The following table is provided as a guide. DO NOT exceed maximum protective device ratings.

Maximum HP Maximum Volts			NEMA Size	Maximum Voltage	Class K5 or R Fuse (Ampere)	Class K1 or J Fuse (Ampere)	Inverse-Time Circuit Breaker (Ampere)	
Single Phase	Three Phase							
115v	230v	208v	250v	600v				
1/2	1	1 1/2	1 1/2	2	00	600	10	15
						250	12	15
1	2	3	3	5	0	600	20	30
						250	25	30
2	3	7 1/2	7 1/2	10	1	600	30	60
						250	40	60
-	-	10	15	25	2	600	60	100
						250	60	100
-	-	25	30	50	3	600	100	200
						250	125	200

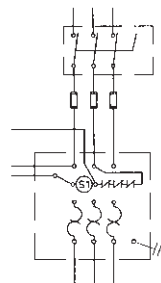

- FIGURE 1 -

When properly installed and given reasonable care and maintenance, regenerative turbine pumps should operate satisfactorily for many years. They do not however have a service life equal to that of low head centrifugal pumps, which are not subjected to the typical differential pressures produced by the regenerative turbine pump. Because of the high differential pressures expected in a regenerative turbine pump, close running clearances are used to reduce internal losses. Abrasive particles, even microscopic ones in high enough concentrations can open up the close clearances between internal cavities. For critical services it is recommended that you keep an identical pump for stand-by use.

PUTTING THE PUMPS INTO SERVICE

Flush unit to drain to remove any debris from receiver. Reinstall Drain Plug.

- A. Remove shipping bracket from each float switch or mechanical alternator as per manufacturer's instructions. (See instruction tag attached to switch.)
- B. Prime the unit by filling the receiver approximately one half (1/2) full of water. **DO NOT Run Pumps dry.** Mechanical seals will be damaged by running pumps dry. **DO NOT Pressurize Receiver.** Receiver has been tested for leaks at the factory. Unit is designed for atmospheric operation only. **DO NOT RESTRICT VENT.**
- C. 3 Phase Units – turn the circuit breaker or float switch control on and immediately off to check direction of shaft rotation. Pump should rotate clockwise viewed from top end of motor. If rotation is backward, interchange any two of the three supply wires.
- D. The float switch has been factory set for maximum capacity of the receiver. Should an alternate setting be required, refer to the float switch manufacturer's instructions.
- E. **Lubrication:** The pump is a close coupled centrifugal unit. The pump has no internal bearings. The motor should be lubricated as recommended by the motor manufacturer.

Make sure total system is free from debris (i.e. pipes, radiators, receivers, etc.)

Make sure all debris has been removed from inlet strainer after start-up of system.

All regenerative turbine pumps have close running clearances in order to maintain efficiency. Take extra precaution to insure that no foreign material larger than 25 microns or .001 inches is allowed to pass through the pump. Even particles of this size will damage the pump if allowed to continue. Regenerative turbine pumps are not designed for slurries.

Large particles, weld spatter and other material found in new piping systems will bend the impeller vanes and can sometimes lock up the pump. If a new pump does not operate properly, the first thing to check for is damage from foreign material.

No adjustments are required or advisable on new pumps. Because of the tight tolerances of regenerative turbine pumps, it is not uncommon for the pumps to be difficult or impossible to turn over by hand after they have been shipped, mounted and allowed to dry out inside. In this case do the following:

1. Fill the pump with fluid.
2. Loosen the thru-bolts **exactly** one turn.
3. Jog the pump momentarily using the test buttons if so equipped.
4. This should "break" the impeller loose without damage, unless foreign material has entered the pump.
5. If possible, spin the pump (or operate with minimal or zero discharge pressure) while the thru-bolts are retightened **exactly** one turn.

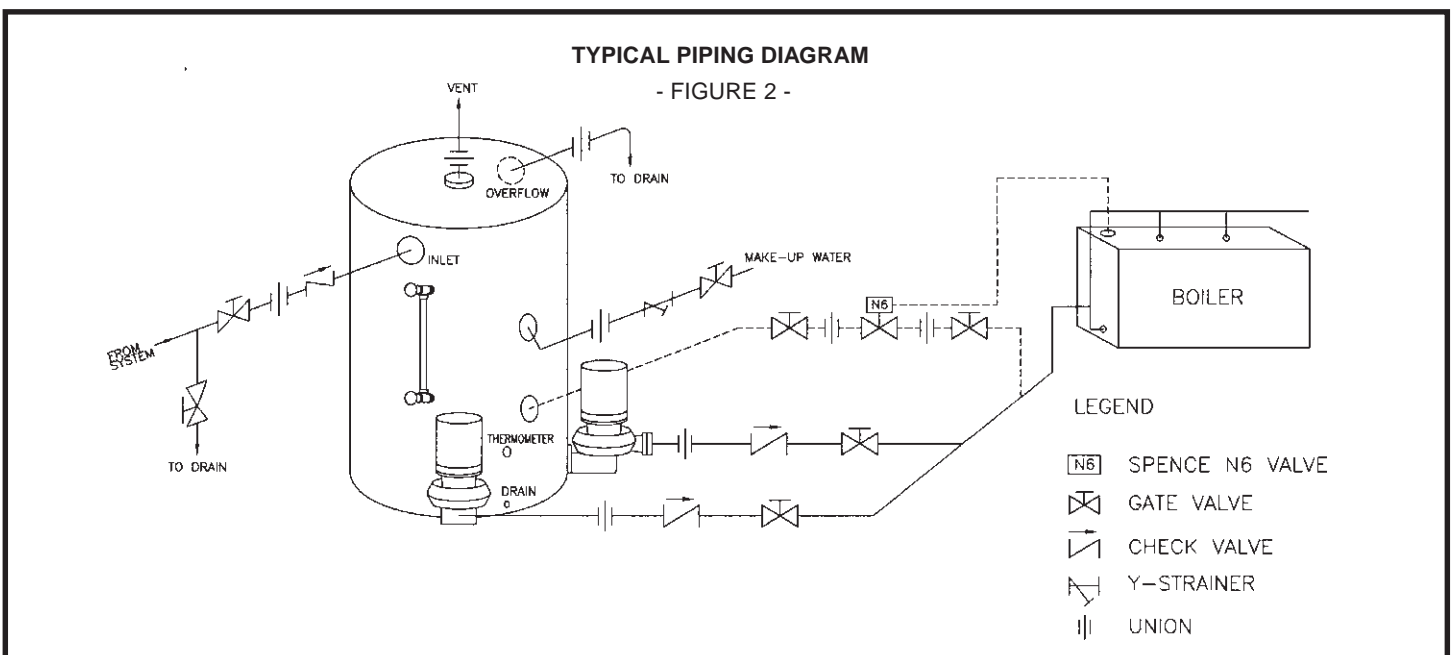
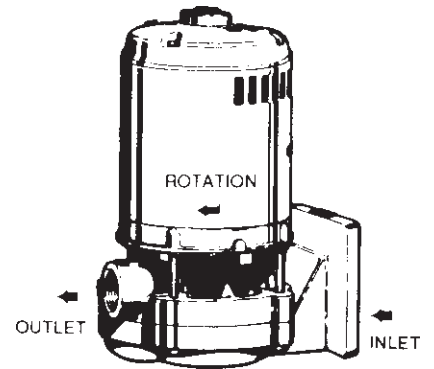

WARNING: The manufacturer will not be liable for any malfunction, damage, or destruction of the equipment if the equipment is not installed properly or is not installed by professionals, licensed and registered as required. Failure to follow and install the equipment according to job specific drawings, made by professionals who are licensed and registered as required and are familiar with the equipment, and failure to have the equipment installed by professionals, who are licensed and registered as required, in accordance with local, state, and federal codes will void all warranties and will void any liability upon the manufacturer. In addition, all warranties, including warranties of merchantability and fitness for a particular purpose are null and void for failure to follow job specific drawings made by professionals who are licensed and registered as required and are familiar with the equipment, and failure to have the equipment installed by professionals, who are licensed and registered as required, in accordance with local, state, and federal codes.

This will flush residue from the close fitting impeller surfaces. If not immediately successful, a vise grip or other plier type gripping device may be used directly on the shaft or lock collar depending on the motor model used. On close coupled units, access to the shaft is between the pump and motor. Applying torque to the motor fan blades is not recommended. The pump should turn before the 50 foot pounds is reached. Continue turning the pump while tightening the thru-bolts to their original positions.

Because of the large areas of close fitting surfaces inside these pumps, it takes only microscopic residue to produce substantial resistance to rotation. Once loosened, this material is quickly dispersed and the impellers find their hydraulic center. If these procedures have been followed, no damage will have resulted from "breaking loose" the impeller.

VALVES

The first valve to be considered for a regenerative turbine pumping system might be a pressure relief valve. Because this type of pump has a horsepower requirement similar to that of a positive displacement pump (constantly rising along with a pressure increase) a relief valve can be effectively used to limit horsepower. This is helpful when a non-overloading motor is specified. It can be of critical importance if the system flow rate can vary widely.

There are almost no circumstances where a flow modulating valve will work successfully in a regenerative turbine pumping system. The steep pumping characteristic, with very large pressure changes as flow rate varies, typical with these pumps, produces shock waves when flow is modulated that can shorten pump life and may cause damage in other pieces of equipment in the system.

If a shutoff valve is necessary in the suction line, use a gate, ball, butterfly, or other full port valve. Globe or other flow restricting valves can in some cases reduce pump flow or increase chances of cavitation.

A swing check valve is recommended in the suction line even when the pump inlet is even slightly higher than the fluid source. It should be the same size as the pump inlet or sized based on reasonable fluid friction losses.

A foot valve is recommended when lifting fluid from a sump. This will save wear and tear on any pump, even those equipped with self-priming equipment.

A Y-Strainer is recommended immediately ahead of the pump on any newly constructed system. This is advisable due to the probability that foreign material large enough to damage pump clearances may remain even though the piping has been flushed.

Valves in the outlet piping of a regenerative turbine pump should always be open as far as possible when the pump is started. This will reduce the start-up load on the pump and motor. Never start the pump with the discharge valve closed.

The inlet valving should be open when starting any pumping system. Without some fluid in the pump, it can gall and lock up impellers. Violent pump failure will result from continued operation with the inlet valve closed.

PRIMING

Regardless of whether self-priming equipment is used or not, always fill the pump and vent it of air for best seal and pump life. Under most circumstances, regenerative turbine pumps can be made to self-prime as long as a small amount of fluid can be recirculated through the impeller and the fluid doesn't heat up noticeably.

NOISE

Regenerative turbine pumps typically produce a high pitched whine that increases in intensity as the differential pressure produced in the pump increases. While high frequency sound is attenuated more easily than lower frequencies, piping structures and the fluids in them readily transmit noise. Motors, bearings, and other rotating components add to noise and sometimes create objectionable harmonics.

Careful pump installation can contribute to noise reduction. Proper alignment of the pump and driver is essential. Adequate supports for the inlet and discharge piping is equally important. A degree of noise reduction may be obtained when the pumping unit is supported free of building structures by the use of vibration isolators and flexible piping and conduit connections. Elastomer type couplings are the best choice to separate motor noises from the fluid and piping structure.

FREEZING

When ambient temperatures drop below the freezing point of the fluid in a pump, consideration should be given to heating, insulating, or draining the pump. If you choose draining the pump and it will be only for a short period, first remove the drain plugs and drain the lines to and from the pump. Carefully blow out the pump with compressed air to clear all internal cavities of fluid.

FLUSHING LINES

If your pump is equipped with external flushing lines, refer to Figure 3 (External Seal Flushing). It is a good idea to confirm that they are open before each operating season or once a year. To do this, unscrew the connections to the seal chamber and install a pipe plug in the seal chamber tap. Jog the pump to confirm that there is flow from the flushing lines. If there is any suspicion that they may be clogged, remove and replace them. Remove the pipe plugs and reconnect the lines when testing is complete.

LUBRICATION

Sealed ball bearings are standard in all pumps. The maximum continuous operating temperature for bearings is 280°F. While it is not advisable to routinely disassemble sealed bearings, it is possible to remove the seals during disassembly and determine their condition. Use new bearings for reassembly. While the pump is in service, listen for unusual sounds or changes in bearing noise. A screwdriver held between the bearing housing and your ear while the pump is rotated by hand is sometimes helpful if there is too much ambient noise when the system is operating.

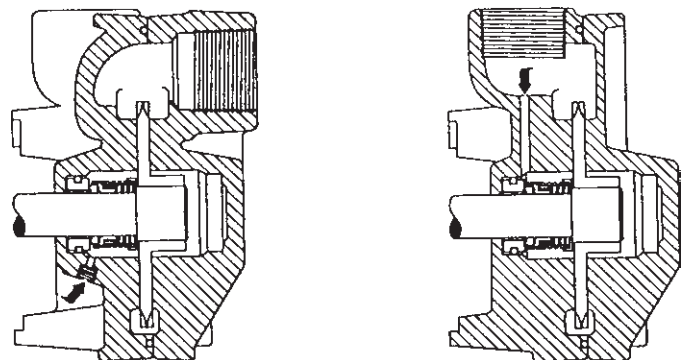

EXTERNAL SEAL FLUSHING

INTERNAL SEAL FLUSHING

- FIGURE 3 -

OPERATION

ROTATION

The standard direction of rotation of the pump is right handed, or clockwise when looking at the motor end of the pump. A rotation arrow (refer to Figure 4) is located on the pump to indicate the correct direction of rotation.

Operating the pump in reverse will cause substantial performance variations and can damage the pump.

Always confirm correct motor rotation prior to connection of the coupling. If this is not possible, or a final rotation check is being performed:

1. Jog the motor briefly.
2. Observe rotation as the unit comes to a stop.
3. Rotation should be in the direction of the arrow.

If the motor operates in the wrong direction:

1. Interchange any two leads on a three phase motor.
2. On a single phase motor, change the leads as indicated on the connection box cover. Some single phase motors may not be reversible.

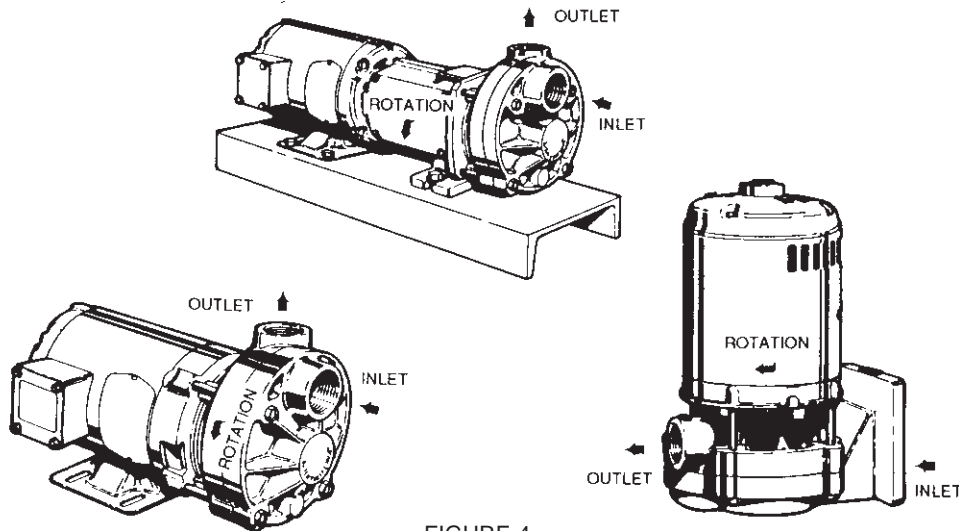

- FIGURE 4 -

INLET AND OUTLET LOCATIONS (Refer to Figure 4)

The pump inlet is located on the end farthest from the motor. The discharge or "outlet" can be on the top, side, or bottom depending on the model and construction of the pump. Normal discharge position is on top.

FOREIGN MATERIAL

All regenerative turbine pumps have close running clearances in order to maintain efficiency. Take extra precaution to insure that no foreign material larger than 25 microns or .001 inches is allowed to pass through the pump. Even particles of this size will damage the pump if allowed to continue. Regenerative turbine pumps are not designed for slurries.

Large particles, weld spatter and other material found in new piping systems will bend the impeller vanes and can sometimes lock up the pump. If a new pump does not operate properly, the first thing to check for is damage from foreign material.

ELECTRICAL

It is important to be aware of and follow the appropriate local and national electrical codes. Do not make wiring alterations that can affect motor rotation without reconfirming correct rotation. Select starter heaters and wiring for the maximum current the motor can use at full service factor loads. Regenerative turbine pumps will typically use extra power for a period until they run in. This can take three to four weeks depending on the duty cycle. During this period, impellers are finding their hydraulically balanced position.

ADJUSTMENTS

No adjustments are required or advisable on new pumps. Because of the tight tolerances of regenerative turbine pumps, it is not uncommon for the pump to be difficult or impossible to turn over by hand after they have been shipped, mounted and allowed to dry out inside. In this case, do the following:

1. Fill the pump with fluid.
2. Loosen the thru-bolts **exactly** one turn.

3. Jog the pump momentarily using the on/off buttons if so equipped.
4. This should "break" the impeller loose without damage, unless foreign material has entered the pump.
5. If possible, spin the pump (or operate with minimal or zero discharge pressure) while the thru-bolts are retightened **exactly** one turn.

This will flush residue from the close fitting impeller surfaces. Because of the large areas of close fitting surfaces inside these pumps, it takes only microscopic residue to produce substantial resistance to rotation. Once loosened, this material is quickly dispersed and the impellers find their hydraulic center. If these procedures have been followed, no damage will have resulted from "breaking loose" the impeller.

PRIMING

Pumps should not be operated unless they are completely filled with liquid. Damage to parts of the pump that depend on liquid for their lubrication can occur. Impellers can seize quickly when a pump is run dry. Without lubrication, seal faces can be damaged from heat buildup.

Pumps can be easily primed with a vacuum pump. An ejector or liquid ring vacuum pump is recommended because they are not damaged if liquid enters them. Connect the vacuum line to the discharge side of the pump, either in the discharge opening or the drain tap. A foot valve is not necessary when this kind of device is used.

There are four components to the self primer:

1. A check valve — necessary to maintain a vacuum in the suction line as surging occurs in the pump.
2. An air eliminator — used on the discharge side of the pump to separate air from liquid so the liquid can be used again as air is carried through the pump.
3. A recirculating line — carries liquid from the air eliminator to the suction.
4. A fluid chamber — used on the inlet side to provide a supply of fluid to speed up priming.

Small suction lines are desirable to minimize priming time.

Using the self-priming casing, it is only necessary to:

1. Open the plugs in both the inlet and discharge chambers.
2. Pour fluid in one until both are full.
3. Tighten both plugs.
4. Turn on the pump.

Priming time depends on lift, volume of air in the suction line, and the size of the regenerative turbine pump used. If priming time is long and the pump becomes warm, refill the priming chambers with fresh liquid. Most turbine pumps will pump twenty-six to twenty-eight inches of mercury vacuum with cold water in the pump, but have very little capacity and therefore are not practical at lifts over twenty-two feet.

The best way to prime a pump and keep it primed is to use a flooded suction. While this is not always practical, it does provide a number of advantages. The likelihood of pump damage from dry running is eliminated. Suction lines may be large, reducing line losses and minimizing the potential of cavitation damage. There are no check

valves or priming devices to fail or require maintenance. Whenever possible design pumping systems with flooded suction.

STARTING

Before starting a pump for the first time, be sure that all the preceding operations have been carried out. Proper rotation, priming and a free turning pump are most important.

1. Start the pump with the minimum possible line restriction.
2. Open discharge valves before pressing the starter.
3. Start the pump and let the system clear of air.
4. Listen for foreign material being carried through the pump.
5. Slowly close necessary valves or otherwise place the pump into service.
6. Listen for indications of undue load or other sounds indicating problems.
7. Use a clip-on ammeter to check for a steady load after approximately fifteen minutes of operation.

MAINTENANCE

SEALS

Mechanical seals are used in pumps to eliminate the type of maintenance that is normally associated with packing boxes. This does not, however, mean that they can be totally ignored. Check a new installation for seal leakage. Early leakage from the inlet end of the pump suggests that either the system was not properly cleared of air before starting and the seal was damaged or there may be an inlet line restriction that was or is letting air in.

Maintenance of seals consists primarily of periodic observation, looking for the first signs of failure. An occasional drip that continues to worsen is an indication that the seal has failed and must be replaced. Follow the appropriate disassembly-reassembly instructions. Always shut down a pump with failed seals as soon as practical. Leaky seals can cause pump damage.

SERVICE

PRELIMINARY

Before attempting any service on the pump or motor, disconnect the electrical power to the pump motor. If the pump and motor are to be removed as a unit, note the wiring configuration. Use colored or numbered tape to mark the wire connections of the motor and power source for reconnection. If the pump is being used to pump hot liquid, let the pump and liquid cool before starting disassembly.

1. Disconnect the inlet and outlet piping before unbolting the pump and motor. If the pipes are corroded, use penetrating oil on the threads to aid in removal.
2. Unbolt the motor from the base and remove the unit. All work on the unit should be performed on an elevated workbench whenever possible.

DISASSEMBLY (C3 AND P3 PUMPS)

The following tools and equipment are needed for disassembly of C3 and P3 Pumps:

1. Soft plastic or wooden mallet.
2. Small ball pein hammer.
3. $\frac{9}{16}$ " wrench or socket.
4. $\frac{5}{32}$ " hex wrench.
5. Penetrating oil.
6. 1" wood dowel (approx. 6" long)
7. Thin blade screwdriver.
8. Two large blade screwdrivers.
9. Cealube G or similar glycol base lubricant. (DO NOT use petroleum products.)

TO DISASSEMBLE THE PUMP

Refer to Figures 8 and 9 for reference to the numbered parts in the procedures below.

1. Remove all liquid from the pump. Air blown through the pump will remove the water quickly.
2. Remove the two (2) nuts (#20), and the two (2) $\frac{3}{8}$ " x 4" bolts (#19) from the cover (#2).
3. Remove the cover. In some cases light tapping with a plastic or wooden mallet on the outside diameter of the cover may be required to loosen it from the motor bracket. Care should be taken if a screwdriver is needed to pry between the cover and motor bracket. Damage to the "O" ring (#7) and/or impeller can result.
4. Remove the impeller (#11), refer to Figure 5. The impeller is a slip fit and, under normal conditions, can be removed by gently tapping on the end of the shaft sleeve with a mallet. Leave the impeller key (#23) in place. Striking the sleeve too hard could damage the seat or rotating element.

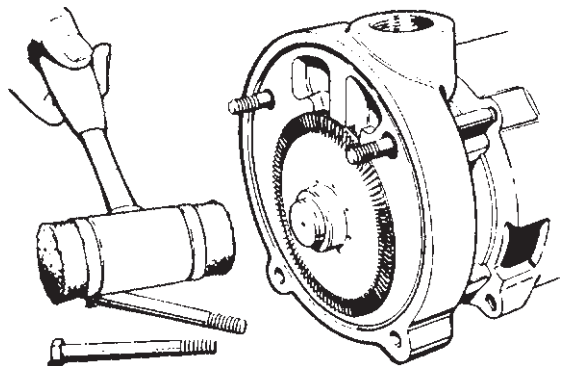

- FIGURE 5 -

5. Using the $\frac{5}{32}$ " hex wrench, loosen the set screws (#15) in the locking collar (#14), located on the shaft sleeve between the motor bracket and the motor base. The collar should now be loose on the sleeve.
6. Remove the shaft sleeve (#17). The sleeve is a keyed fit and is removed using two large screwdrivers. Refer to Figure 6.

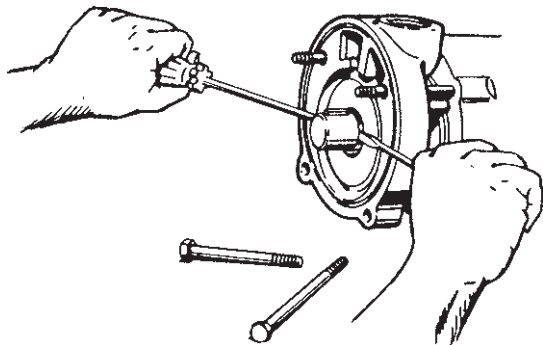

- FIGURE 6 -

- a. Insert the blades of the screwdrivers between the springholder on the rotating element and the shoulder of the shaft sleeve.
 - b. Holding the screwdrivers at approximately 3 o'clock and 9 o'clock, push the handles in toward the motor body, using the motor bracket for leverage.
7. In some cases a rocking motion of the screwdrivers will be necessary to break the sleeve loose. Normally the rotating element will slide off with the sleeve. DO NOT attempt to remove the sleeve by rotating it. (Previous models have used a threaded shaft, and different procedures are required in these cases.)
 8. Remove the rotating element from the sleeve. Refer to Figure 7. The element normally adheres tightly to the sleeve and some force may be necessary to remove it. This is common and if care is taken, the element can be reassembled and reused. **It is recommended that a new rotating element be used for reassembly.** DO NOT attempt to remove the seal using a screwdriver or other sharp object. Extensive damage to the shaft, sleeve, or element could occur.

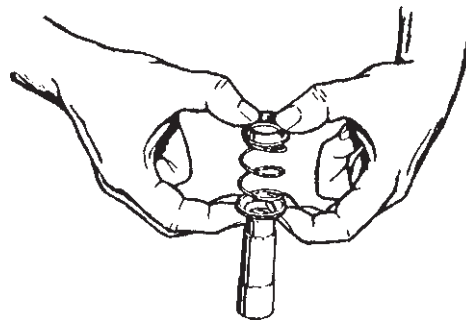

- FIGURE 7 -

9. Before the motor bracket (#1) can be removed, the four (4) "O" rings (#8), located on the upper left and right studs must be removed.
 - a. Gently tap on the back of the motor bracket, alternating between the left and right side, until the motor bracket moves approximately $\frac{1}{4}$ ".
 - b. Tap the motor bracket face to move it back to its original position.
 - c. Remove the "O" rings by sliding them off the studs.
 - d. Slide the motor bracket straight off. Do not attempt to remove the motor bracket without first removing the "O" rings (#8).
10. Remove the seat portion of the seal. Refer to Figure 10.
 - a. Place the motor bracket face down on a flat surface.
 - b. Look into the opening in the center of the bracket; you will see a portion of the seat.
 - c. Insert the 1" dowel and, very gently, tap the seat until it drops out.
 - d. Care must be taken with the seats. They are often a brittle material and are prone to breakage. **It is recommended that a new replacement seat be installed during reassembly.**

Part No.	Name/Description	Quantity
1	Motor Bracket	1
2	Cover	1
7	"O" Ring/Casing	1
8	"O" Ring/Guide Rod	4
11	Impeller	1
12	Seal Rotating Element	1
125	Seal Stationary Seat	1
14	Lock Collar/Sleeve	1
15	Setscrew/Lock Collar	2
17	Shaft Sleeve	1
18	Guide Rod (quan. 4 on Stainless Steel)	2
19	ThruBolt (quan. 0 on Stainless Steel)	2
20	Nut (quan. 4 on Stainless Steel)	2
22	Pipe Plug/Drain	1
23	Key/Impeller Drive	1
23A	Key/Sleeve Drive	1

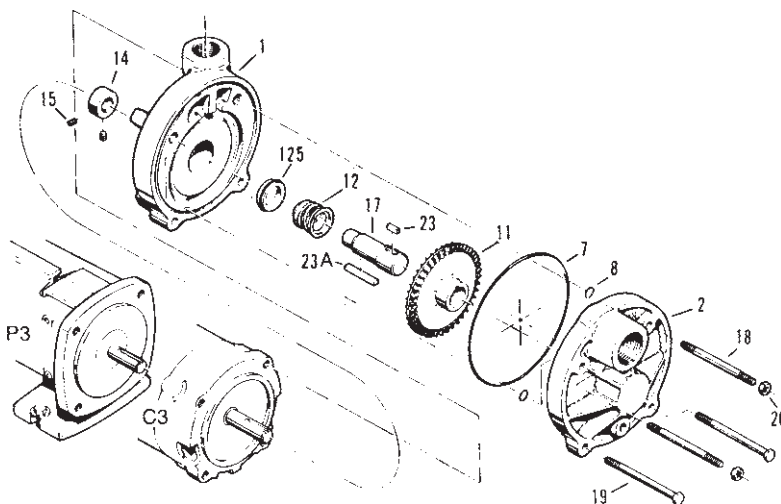

22 Drain Plug (not shown)

C3 - P3 CLOSE COUPLED PUMP

- FIGURE 8 -

Part No.	Name/Description	Quantity
1	Motor Bracket	1
2	Cover/Vertical	1
7	"O" Ring/Casing	1
8	"O" Ring/Guide Rod	4
11	Impeller	1
12	Seal Rotating Element	1
125	Seal Stationary Seat	1
14	Lock Collar/Sleeve	1
15	Setscrew/Lock Collar	2
17	Shaft Sleeve	1
18	Guide Rod	2
19	ThruBolt	2
20	Nut	2
22	Pipe Plug/Drain	1
23	Key/Impeller Drive	1
23A	Key/Sleeve Drive	1
60	Gasket	1

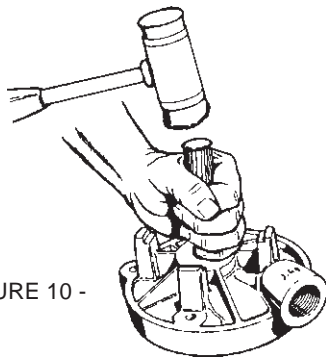

- FIGURE 10 -

11. It is not necessary to remove the locking collar (#14) on the motor shaft unless motor repairs are planned. Note the condition of the setscrew in the collar and replace if necessary. The two studs (#18) may also be left in the motor face.

DISASSEMBLY (C15 AND P15 PUMPS)

The following tools and equipment are needed for disassembly of C15 and P15 pumps.

1. Soft plastic or wooden mallet.
2. Small ball peen hammer.
3. $\frac{9}{16}$ " wrench or socket.
4. Two 10" or larger adjustable wrenches.
5. Penetrating oil.
6. 1" wood dowel (approx. 6" long).
7. Thin blade screwdriver.
8. Two large blade screwdrivers.
9. Cealube G or similar glycol base lubricant. (DO NOT use petroleum products.)

TO DISASSEMBLE PUMP

Refer to Figures 15 and 16 for reference to the numbered parts in the disassembly below.

1. Remove all liquid from the pump.
2. Remove the two (2) $\frac{3}{8}$ " nuts (#20), and the two (2) $\frac{3}{8}$ " x 4" bolts (#19) from the cover. (#2)
3. Remove the cover. In some cases light tapping with a plastic or wooden mallet on the outside diameter of the cover may be required to loosen it from the motor bracket. Care should be taken if a screwdriver is needed to pry between the cover and motor bracket. Damage to the "O" ring (#7) and/or impeller can result.

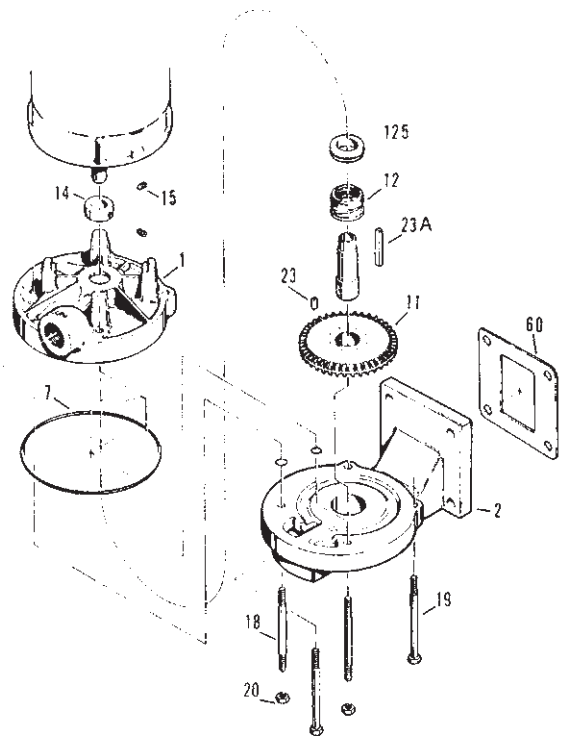

C3 VERTICAL FLANGE MOUNT PUMP

- FIGURE 9 -

4. Remove the impeller (#11). Refer to Figure 11. The impeller is a slip fit and, under normal conditions, can be removed by gently tapping on the end of the shaft sleeve with a mallet. Leave the impeller key (#23) in place. Striking the sleeve too hard could damage the seat or rotating element.

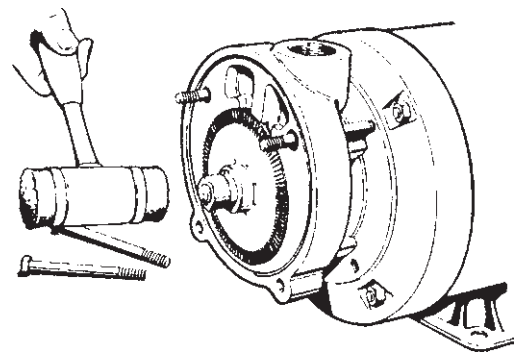

- FIGURE 11 -

5. Remove the impeller drive hub. Refer to Figure 12. Two (2) adjustable wrenches are used to remove the impeller drive hub (#14).
 - a. Adjust one wrench to fit over the sleeve and engage the impeller key. Adjust the second wrench to fit the impeller nut (#15).
 - b. Holding both wrenches, turn the impeller nut counterclockwise.
 - c. After the impeller nut is removed the impeller drive hub can be removed.
 - d. The hub is keyed and can be removed using two large bladed screwdrivers.
 - e. Insert the blades of the screwdrivers between the springholders of the rotating element.
 - f. Holding the screwdrivers at approximately 3 o'clock and 9 o'clock, push the handles in toward the motor body, using the motor bracket for leverage. Refer to Figure 13. This procedure usually does not require excessive force. Care should be taken not to damage the hub or motor shaft.

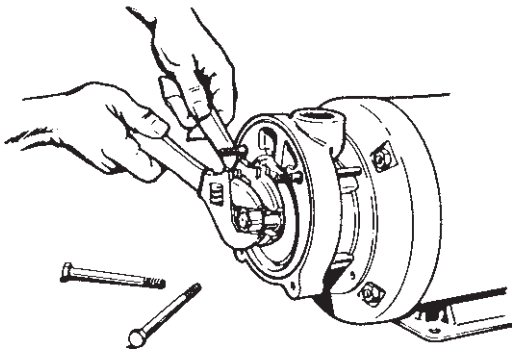

- FIGURE 12 -

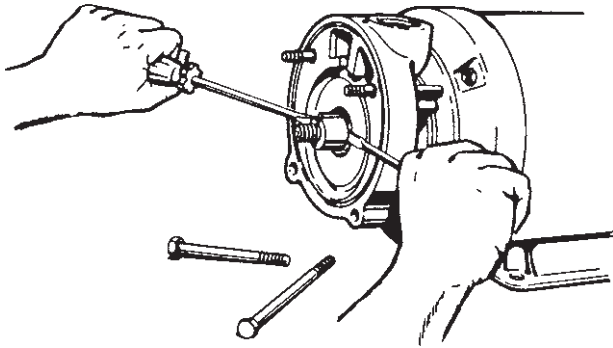

- FIGURE 13 -

6. Remove the rotating element from the sleeve. The element normally adheres tightly to the motor shaft and some force may be necessary to remove it. This is common and if care is taken, the element can be reassembled and reused. **It is recommended that a new rotating element be used for reassembly.** DO NOT attempt to remove the seal using a screwdriver or other sharp object. Damage to the shaft, sleeve, or element can occur.

7. Before the motor bracket (#1) can be removed, the four (4) "O" rings (#8), located on the upper left and right studs must be removed.
 - a. Gently tap on the back of the motor bracket, alternating between the left and right side, until the motor bracket moves approximately 1/4".
 - b. Tap the motor bracket face to move it back to its original position.
 - c. Remove the "O" rings by sliding them off the studs.
 - d. Slide the motor bracket straight off. Never attempt to remove the motor bracket without first removing the "O" rings (#8).
8. Remove the seat portion of the seal. Refer to Figure 14.
 - a. Place the motor bracket face down on a flat surface.
 - b. Look into the opening in the center of the bracket; you will see a portion of the seat.
 - c. Insert the 1" dowel and, very gently, tap the seat until it drops out. Care must be taken with the seats. They are often a brittle material and are prone to breakage.

It is recommended that a new replacement seat be installed during reassembly.

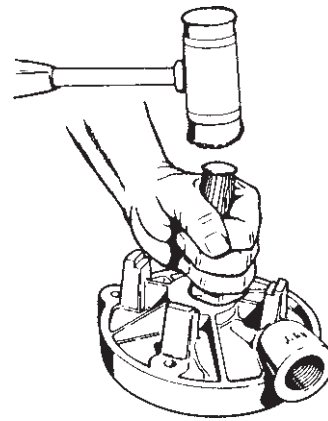

- FIGURE 14 -

Part No.	Name/Description	Quantity
1	Motor Bracket	1
2	Cover	1
7	"O" Ring/Casing	1
8	"O" Ring/Guide Rod	4
11	Impeller	1
12	Seal Rotating Element	1
125	Seal Stationary Seat	1
14	Drive Sleeve/Impeller Driver	1
15	Impeller Nut	2
18	Guide Rod	2
19	ThruBolt	2
20	Nut	2
22	Pipe Plug/Drain	1
23	Key/Impeller Drive	1
23A	Key/Sleeve Drive	1

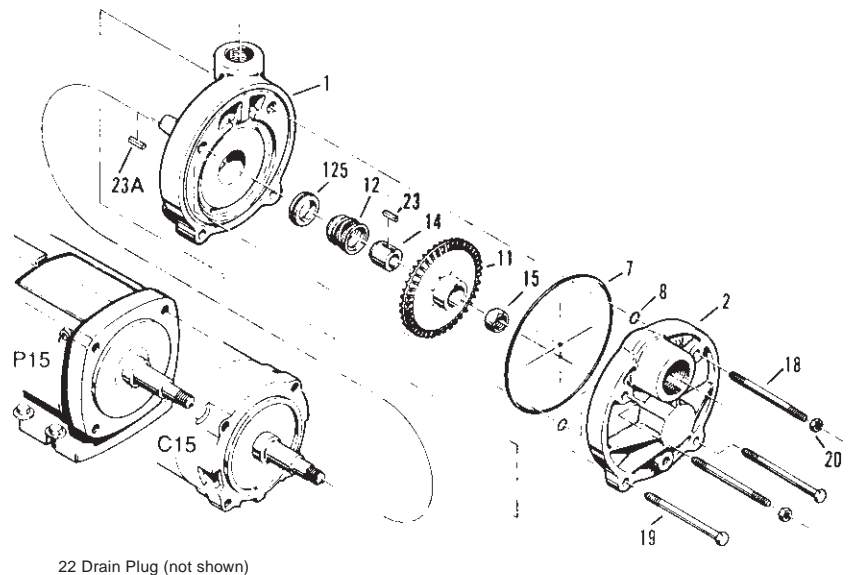

22 Drain Plug (not shown)

C15 - P15 CLOSE COUPLED PUMP

- FIGURE 15 -

Part No.	Name/Description	Quantity
1	Motor Bracket	1
2	Cover/Vertical	1
7	"O" Ring/Casing	1
8	"O" Ring/Guide Rod	4
11	Impeller	1
12	Seal Rotating Element	1
125	Seal Stationary Seat	1
14	Drive Sleeve/Impeller Driver	1
15	Impeller Nut	1
18	Guide Rod	2
19	ThruBolt	2
20	Nut	2
23	Key/Impeller Drive	1
23A	Key/Sleeve Drive	1
60	Gasket	1

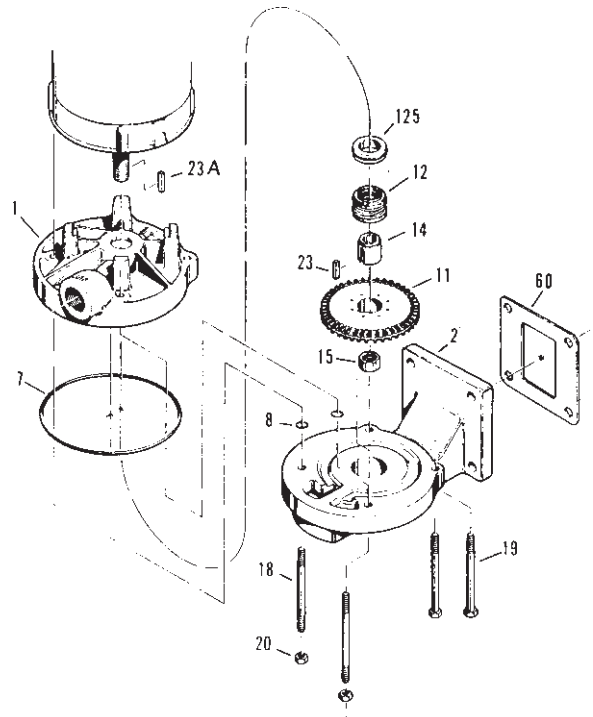

C15 VERTICAL FLANGE MOUNT PUMP

- FIGURE 16 -

INSPECTION OF COMPONENTS

Thoroughly clean all parts. All components should be examined for wear and corrosion. Replace any parts that show visible wear. If the pump was not producing sufficient pressure or capacity, the clearances between the rings and impeller probably exceed the maximum allowable clearance. At minimum the impellers should be replaced in this case. If the total side running clearance for an impeller exceeds .007", it is unlikely that pump performance will reach that of a new pump except at lower discharge pressures.

The "O" rings and other elastomeric components should be replaced if they have been deformed or cut.

If seal components must be reused, carefully inspect for microscopic cracks and nicks. Scratches that might be ignored elsewhere can produce leakage if they are on seal carbons and seat wearing surfaces.

Cleanliness is imperative when working with mechanical seals. Almost unnoticeable particles between seal faces can be, and often are, the cause of early seal failures.

Check the impellers. They are designed to float. They should move easily on the shaft. As long as they can be moved on the shaft by hand, they are loose enough. If the impeller can be rocked or wobbled, it is too loose and must be replaced.

Check the sleeve or shaft for galling, pitting, and corrosion. If the shaft or sleeve is corroded where the seal comes in contact with them, the shaft or sleeve must be replaced. Surface corrosion must be removed so that seals can slide freely during assembly. The shaft diameter should be no smaller than .002" below the nominal fractional seal sizes. Remove any nicks or burrs which may have occurred during disassembly. Reclean parts as necessary.

REASSEMBLY (C3 AND P3 PUMPS)

All parts should be visually inspected and cleaned or replaced as outlined in *Inspection of Components* above.

1. The seal seat (#125) must be installed in the motor bracket before the bracket is installed on the motor. To install the seat:
 - a. Place the motor bracket face up on a flat surface.
 - b. Carefully press the seat, smooth side up, into the seat cavity of the motor bracket. To make the installation of the seat easier, apply a thin coating of compatible lubricant to the elastomer portion of the seat prior to installation. Care must be taken not to damage the seat face. Thumb pressure is usually sufficient to install the seat.
2. Install the motor bracket.
 - a. Make sure the locking collar is positioned on the motor shaft.
 - b. While holding the motor bracket with the outlet port facing up, slide the bracket over the two (2) studs on the motor face.
 - c. Slide the bracket back until the feet are resting against the motor face. Light tapping may be necessary to seat the motor bracket in the proper position.

- d. Install the four (4) "O" rings (#8) on the two studs. This will help hold the bracket in place during the remainder of the assembly operation.
3. Install the shaft sleeve and rotating element as a unit.
 - a. Place the sleeve in an upright position with the smaller end facing up.
 - b. Lubricate the shaft sleeve and rotating element.
 - c. Holding the element assembly between the thumb and index finger of both hands, refer to Figure 17, slide the assembly over the sleeve until the spring holder rests against the shoulder of the sleeve.

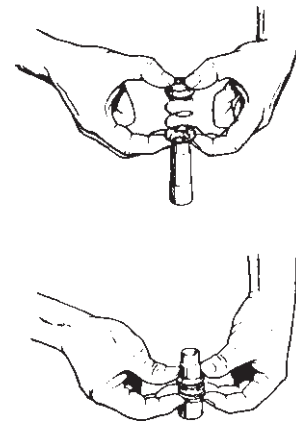

- FIGURE 17 -

- d. The element must slide freely up and down on the sleeve. It is necessary to maintain some downward pressure on the element because the spring tension could dislodge the seal portion of the element.
- e. Be sure to install a key (#23A) in the motor shaft before installing the sleeve and seal assembly.
- f. Holding the assembled sleeve between the thumb and index finger, slide the assembly onto the motor shaft.
- g. Push the sleeve on until it comes in contact with the locking collar.

- h. Position the collar over the sleeve end and push the sleeve on until it stops.
 - i. While maintaining inward pressure on the sleeve with one hand, line up the collar setscrew with the key in the shaft sleeve.
 - j. Tighten the setscrew snugly.
 - k. Pressure can now be released; the sleeve should remain in position. The spring holder must be below the impeller wearing surface of the motor bracket for proper impeller operation.
4. Install the impeller.
 - a. Place a key (#23) in the shaft sleeve.
 - b. The impeller is a slip fit and should slide on firmly but easily until it stops against the impeller wearing surface. Force should not be required to install the impeller in the correct position.
 - c. The impeller hub should be facing out away from the motor bracket. Refer to Figures 8 and 9.
 - d. If the impeller does not fit redo steps a. and b. to determine the problem.
 5. Place "O" ring (#7) into the "O" ring groove in the motor bracket. It is helpful to stand the motor and pump assembly on end for this procedure.
 6. Place the cover over the studs and install the (2) $\frac{3}{8}$ " nuts and (2) $\frac{3}{8}$ " x 4" bolts. Tighten the nuts and bolts systematically, alternating diagonally across the cover.
 7. After the nuts and bolts are "snugged up" make sure the impeller is not binding by inserting a $\frac{5}{32}$ " hex wrench into the locking collar and moving it left to right. The collar should rotate with little or no resistance. If the collar will not turn, loosen the two (2) $\frac{3}{8}$ " nuts and bolts equally until the impeller moves freely.

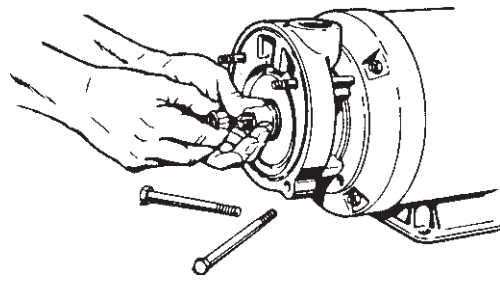

- FIGURE 19 -

- b. Lubricate the motor shaft with a small amount of glycol base lubricant.
- c. It is generally easier to remove the entire head or sealing assembly from the spring and install it on the motor shaft. Refer to Figure 18. This assembly lifts out of the rotating element spring.
- d. After removal, apply a thin layer of lubricant to the elastomer portion of the seal.
- e. Holding the head assembly between the thumb, forefinger, and index finger with the sealing face pointing toward the stationary seat, slide the assembly over the motor shaft until it rests against the seat. Refer to Figure 20. A slight twisting motion will cause the assembly to slide easier.
- f. Check to see that the head assembly is against the seat face.
- g. Position the rotating element spring with the spring holder resting against the shoulder of the sleeve hub.
- h. Align the keyway slot in the hub assembly (refer to Figure 20) and the key in the motor shaft.
- i. Slide the hub and spring assembly over the shaft until the hub is properly seated and the spring is positioned correctly on the rotating element head previously installed. Refer to Figures 15 and 16.
- j. While maintaining inward pressure on the hub, install the impeller nut. Refer to Figure 19.
- k. Tighten the nut as far as possible by hand.
- l. Pressure can now be released.
- m. To tighten the nut, place a crescent wrench over the hub sleeve and engage the drive key.
- n. Place a second crescent wrench over the nut and tighten in a clockwise direction until it is secured. Refer to Figure 21.

REASSEMBLY (C15 AND P15 PUMPS)

All parts should be visually inspected and cleaned or replaced as outlined in *Inspection of Components* Section.

1. The stationary seat (#125) must be installed in the motor bracket before the bracket is installed on the motor. To install the seat:
 - a. Place the motor bracket face up on a flat surface.
 - b. To make the installation of the seat easier, apply a thin coating of compatible lubricant to the elastomer portion of the seat prior to installation.
 - c. Carefully press the seat, smooth side up, into the seat cavity of the motor bracket. Care must be taken not to damage the seat face. Thumb pressure is usually sufficient to install the seat.
2. Install the motor bracket.
 - a. While holding the motor bracket with the outlet port facing up, slide the bracket over the two (2) studs (#18) on the motor face.
 - b. Slide the bracket back until the feet are resting against the motor face. Light tapping may be necessary to seat the motor bracket in the proper position.
 - c. Install the four (4) "O" rings (#8) on the two studs. This will help hold the bracket in place during the remainder of the assembly operation.

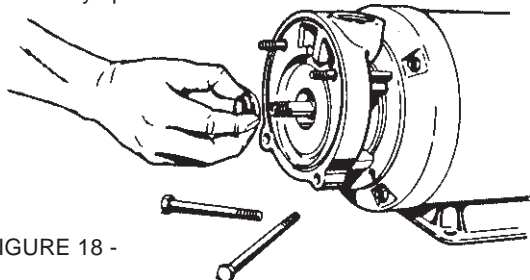

- FIGURE 18 -

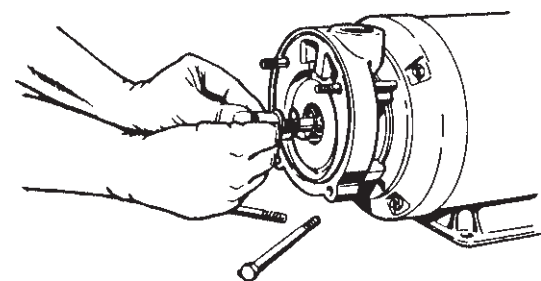

- FIGURE 20 -

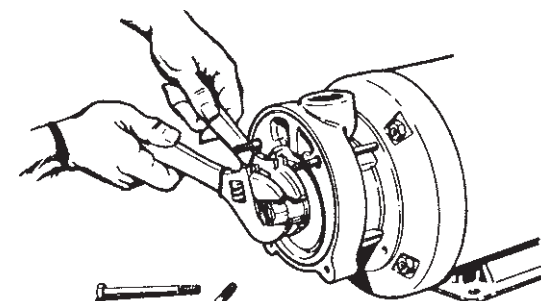

- FIGURE 21 -

3. Install the sleeve hub and rotating element as a unit.
 - a. Place the sleeve in an upright position with the smaller end facing up.

4. Install the impeller.
 - a. The impeller is a slip fit and should slide on firmly but easily until it stops against the impeller wearing surface. Force should not be required to install the impeller in the correct position.
 - b. The impeller hub should be facing out away from the motor bracket.
 - c. If the impeller does not fit redo steps a. and b. to determine the problem.
5. Place "O" ring (#7) into the "O" ring groove in the motor bracket. It is helpful to stand the motor and pump assembly on end for this procedure.
6. Place the cover over the studs and install the two (2) $\frac{3}{8}$ " nuts and two (2) $\frac{3}{8}$ " x 4" bolts. Tighten the nuts and bolts systematically, alternating diagonally across the cover. Do not overtighten the nuts and bolts; final adjustment will be made after the unit is in operation.

1. Reconnect the electrical connections referring to the colored or numbered tape used to mark the wires.
2. Connect all piping and fill the pump with fluid.
3. Make sure all valves are opened and fluid will flow through the system.
4. Start the pump and make the final adjustments to the $\frac{3}{8}$ " nuts and bolts holding the cover on. These nuts and bolts must be torqued to 20 ft. lbs. to obtain proper performance.
5. Check for leaks on pump and piping. Special attention should be given to the seal area at the rear opening in the motor bracket.
6. Under pressure, the impeller will find its "hydraulic" balance.
7. Using an amprobe or similar device, check for motor overload.
8. While the impeller is seating it is common to experience some variance in readings. After a run-in period the readings should level off.

This completes the adjustment and testing phase. The pump is ready for service.

TESTING AND FINAL ADJUSTMENT

The pump is now ready for installation. Final adjustments will be made with the pump in operation.

TROUBLESHOOTING

FAILURE TO PUMP

1. Pump not up to speed—
Use tachometer to determine actual RPM. Check voltage and wiring connections.
2. Pump not primed—
Confirm that pump and all inlet piping are filled with fluid.
3. Discharge head too high—
Install a pressure gauge at the pump discharge to determine the actual operating pressure. Compare readings with pump performance curve. A larger pump may be necessary.
4. Excessive suction lift—
Relocate pump, supply tank or both to minimize suction lift.
5. Wrong direction of rotation—
Compare pump rotation with arrow on pump. Standard pumps rotate in a clockwise direction when looking at the shaft extension end. Clockwise from the motor end on close coupled pumps. Reverse two leads on a three phase motor to change rotation. Check motor nameplate for single phase operation.
6. Clogged suction line, strainer or foot valve—
Inspect and clean out if necessary.
7. Air pocket in suction line—
Look for high spots in inlet piping system. Evacuate the system with a vacuum pump if necessary.

REDUCED CAPACITY

1. Pump not up to speed—
Use a tachometer to determine actual RPM. Check voltage and wiring connections.
2. Excessive suction lift—
Relocate pump, supply tank or both to minimize suction lift.
3. Insufficient NPSH—
Relocate pump, supply tank or both to improve NPSH available if possible. Increase suction pressure. Reduce fluid temperature.
4. Mechanical damage—
Rotate the pump by hand to determine if there are tight spots. Broken or bent impeller vanes can sometimes be noticed in this manner. If there is suspicion of damage, remove the pump from service and disassemble for inspection.
5. Air leak in the suction line—
Fill the system with fluid and hydrostatically test. Tighten connections or replace leaky components.

6. Air pockets in the suction piping—

Operating the system at maximum flow conditions will usually clear the lines. Evacuate the system with a vacuum pump if necessary.

7. Suction lines, strainer or foot valve too small or clogged—
Inspect and clean out as necessary. Fittings and lines should be at least equal to the pump suction size.
8. Discharge head too high—
Install a pressure gauge at the pump discharge to determine the actual operating pressure. Compare readings with pump performance curve. A larger pump may be necessary.
9. Excessive wear—
If a pump had previously performed satisfactorily and now gives evidence of reduced performance, it should be disassembled and examined for wear after the simpler possible problems have been pursued.

REDUCED PRESSURE

1. Pump not up to speed—
Use a tachometer to determine actual RPM. Check voltage and wiring connections.
2. Air or vapor in liquid—
Install a separator in the suction line. Check the seal on the inlet end of the pump to determine if air is being drawn in. Hydrostatically test the system to insure that there are no leaks.
3. Mechanical wear or damage—
Rotate the pump by hand to determine if there are tight spots. Broken or bent impeller vanes can sometimes be noticed in this manner. If there is suspicion of damage or wear, remove the pump from service and disassemble for inspection. Look for wear on the impeller, suction cover, and motor bracket.
4. System head less than expected—
Replace pump with higher capacity unit or add a valve or orifice to increase line resistance.

PUMP LOSES PRIME AFTER STARTING

1. Leak in suction line—
Fill the system with fluid and hydrostatically test. Tighten connections or replace leaky components.
2. Air entering pump through inlet seal or "O" rings—
Hydrostatically test the pump looking for leaks. Replace faulty seals or "O" rings.
3. Insufficient NPSH or too much suction lift—
Relocate pump, supply tank or both to improve inlet conditions. Increase suction pressure. Reduce fluid temperature. Select a pump with lower NPSH requirements.

EXCESSIVE POWER CONSUMPTION

1. Speed too high—
Check RPM with tachometer.
2. Discharge head too high—
Install a pressure gauge at the discharge to determine the actual operating pressure. Compare readings with pump performance curve. A different pump, motor or both may be necessary.
3. Specify gravity or viscosity too high—
Check fluid involved. A different motor may be necessary.
4. Mechanical damage—
Turn pump over by hand. After a few days run-in period, all models should turn over by hand with no sticky spots. An exception to this is when the pump has been idle for some time. In this case, run the pump for a few hours before checking for sticky spots. If there is suspicion of damage, remove the pump from service and disassemble for inspection.
5. Pump not fully broken in—
It is normal for new pumps to consume higher than normal current during the break-in period. If high power consumption persists beyond a few weeks, it is unlikely that further operation will reduce consumption.
6. Pump not properly adjusted—
Loosen all nuts on pump **exactly** one turn.

PUMP VIBRATES OR IS NOISY

1. Pump and motor are misaligned—
Follow the installation instructions for proper alignment.
2. Piping load on pump—
Install piping supports and check to see that there is no strain on the pump.
3. Mechanical damage—
If mechanical damage is suspected, check first to determine if pump turns freely. Disassemble for inspection if sticky spots are found.
4. Pump has a high pitched whine—
This is typical of a regenerative turbine pump. The intensity should increase as pressure increases. Over a period of a few weeks the noise level will diminish and will be noticeably quieter as it approaches a run-in condition.

MECHANICAL PROBLEMS

1. Short bearing life—
Bearings damaged due to leaky seals. Coupling misalignment. Piping load on pump. RPM or pump pressure too high.
2. Pump locked up—
Pump dried out and close clearances rusty. Follow installation instructions for loosening the pump. Foreign material in pump. Flush out. Disassemble if flushing is not successful.
3. Pump leaks—
Seal or "O" rings are usually the problem. Disassembly and replacement is the solution if tightening the thru bolts has no effect.

SEAL LEAKAGE

1. Worn seat or rotating element—
Seals will last many years operating on cold clear water or other fluids with reasonable lubricity. Particles, even microscopic, increase normal wear rates. Temperatures near the fluid's boiling point can reduce lubricity which in turn increases wear. Some chemicals will erode the seal faces or plate out on the faces, producing an abrasive effect. Immediate seal replacement is recommended when leaks become evident since bearings are quickly ruined as a result of moisture. Severe mechanical damage results when the bearings fail.
2. Improperly installed seat or rotating element—
If a seal has recently been replaced, look for a missing "O" ring around the seat, or a seat that is in cocked or backwards. The smooth surface should face the rotating element. The rotating element may be in backwards or improperly positioned. Refer to the appropriate seal diagrams and instructions to confirm the correct seal orientation. Rotating elements sometimes stick in the wrong position if left partially assembled for some time. Make sure a rotating element can be moved axially on the shaft before closing up the pump and then make the final adjustments as soon as possible.
3. Seat broken during assembly—
Ceramic seats are particularly vulnerable to damage. Carefully follow reassembly instructions for seals. Seals on flex coupled units can be damaged by overzealous hammering when installing the shaft coupling onto the pump.
4. Pitted shaft under the seal—
Reusing a shaft or sleeve when repairing a pump is the probable cause of this problem. The seal rotating element can produce a pitted surface underneath its elastomer portion during normal use. This is normally not a problem for the first seal assembly since the elastomer is conforming as this action occurs. A new seal can leak before it conforms if the pits are large enough. If any pits are visible to the unaided eye, shaft or sleeve replacement is advised.