



Installation, Operation and Maintenance Information

Type EVC Vacuum and Condensate Pumps

Caution: The Unit receivers are not designed for internal pressure. DO NOT PRESSURIZE RECEIVERS.

SITE INSPECTION

The unit should be of the proper size and capacity for the proposed installation. Refer to nameplate for rated capacities. Check motor and control voltages with the available power supply.

UNIT LOCATION

Standard units are designed with O.D.P. (Open Drip Proof) Motors and NEMA I controls. Other classifications are available — check unit detail sheet for classification supplied. Locate unit only in areas of the proper classification. The unit should be located to allow for removal of pumps for replacement of seals. If a housekeeping pad is used, do not extend foundation under pump and motor assemblies.

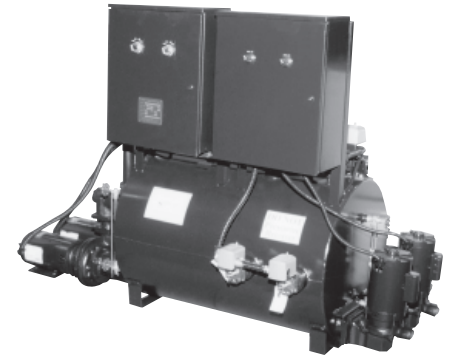

VENT CONNECTION

Install a full sized vent to atmosphere from the vacuum receiver. (See piping diagram.) DO NOT install any shut-off valves or other type of valves in the vent line. Do not plug vent to test system for leaks. Receiver is not made to be pressurized.

OVERFLOW

Install overflow piping from the vacuum receiver to drain. (See piping diagram.)

RETURN PIPING

Connect condensate return lines to the condensate receiver through a full ported gate valve. The return lines should be pitched toward the receiver to insure gravity flow.

CAUTION: Avoid piping restrictions immediately ahead of the condensate receiver, i.e., elbows, tees, etc. Locate these at least 10 times the inlet diameter ahead of the inlet strainer (ex. 3" inlet 30" ahead of strainer).

DISCHARGE PIPING (Condensate Pumps)

Install a union immediately beyond the pump discharge. A check valve should be installed in the discharge piping close to the pump to prevent back flow into the unit. **A throttling valve (ball valves, globe valves or steam cock) must be installed after the check valve close to the pump.**

ELECTRICAL WIRING

Units are furnished for most popular voltages. Make sure the motor wiring, starters, transformers, etc., match the power supply. Controls, starter coils, etc., should match the control voltages. The control circuit is the secondary side of transformers when furnished.

Single phase motors are usually furnished as dual voltage 115/230/1/60. Motors should be connected according to manufacturer's instructions for correct voltage.

Three phase motors are usually furnished as tri-voltage 208/230/460/3/60. Motors should be connected according to manufacturer's instructions for correct voltage.

Control panels furnished with the unit should have the nameplate data match the supply current. Should the nameplate data not match the power supply, consult factory.

Wire in accordance with the National Electrical Code and Local Codes where applicable.

Single phase drip proof motors up to and including 1 HP have built-in thermal overload protection. Magnetic starters are not required on these motors.

Single phase drip proof motors larger than 1 HP and all three phase motors require magnetic starters.

SHORT CIRCUIT PROTECTION

According to the National Electrical Code, branch circuit overcurrent protection must be provided for each contactor or starter. The following table is provided as a guide. DO NOT EXCEED MAXIMUM PROTECTIVE DEVICE RATINGS.

Maximum HP Maximum Volts					NEMA Size	Maximum Voltage	Class K5 or R Fuse (Ampere)	Class K1 or J Fuse (Ampere)	Inverse-Time Circuit Breaker (Ampere)
Single Phase 115v	230v	Three Phase 208v 250v 600v							
1/3	1	1 1/2	1 1/2	2	00	600	10	15	15
						250	12	15	15
1	2	3	3	5	0	600	20	30	20
						250	25	30	35
2	3	7 1/2	7 1/2	10	1	600	30	60	40
						250	40	60	60
—	—	10	15	25	2	600	60	100	80
						250	60	100	90
—	—	25	30	50	3	600	100	200	125
						250	125	200	150

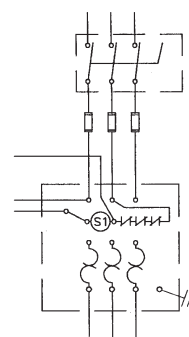

FIGURE 1

FRESH WATER SUPPLY TO VACUUM RECEIVER

Install a valved fresh water supply line, which should be piped to the solenoid valve mounted on top of the vacuum receiver. A float switch, located in the equalizing line below the overflow connection, controls the solenoid valve. This switch is factory preset to maintain the proper water level in the vacuum receiver.

TEMPERATURE LIMIT SWITCH(ES) (when furnished)

A temperature limit switch may be installed on the vacuum receiver. This switch is used to control the solenoid valve and allow cooling water to enter the vacuum receiver when the temperature exceeds the predetermined switch setting.

A temperature limit switch may also be installed on the condensate receiver. This switch is used when the temperature of the condensate fluctuates to a temperature where the condensate would vaporize under vacuum and possibly cause condensate pump cavitation. This temperature limit switch is used to prohibit the vacuum pumps from running under adverse conditions.

VACUUM SWITCHES AND ADJUSTMENTS

The vacuum switch(es) are factory preset for proper operation. Should field adjustments be required, the vacuum switch on a single unit and the lead vacuum switch on a duplex unit is set to close at 3" Hg and open at 8" Hg. The lag switch on a duplex unit is set to close at 2" Hg and open at 8" Hg. Refer to manufacturer's instructions for specific details.

FLOAT SWITCH(ES)

The float switch(es) has been factory set for maximum condensate receiver capacity. Should an alternate setting be required, refer to the float switch manufacturer's instructions.

MECHANICAL ALTERNATOR (when furnished)

The mechanical alternator is furnished in lieu of float switches on duplex condensate pumping units. The action of the mechanism is such that two switch units are alternated on successive cycles. The mechanical alternator will also provide simultaneous operation of the second or stand-by pump on a high water level condition. Should an alternate setting be required, refer to the mechanical alternator manufacturer's instructions.

PUTTING THE PUMPS INTO SERVICE

Flush unit to Drain (vacuum and condensate receivers) to remove any debris from receiver(s). Reinstall Drain Plug(s).

- A. Check piping in system with Typical Piping Diagram in this manual.
- B. Remove shipping bracket from each float switch or mechanical alternator as per manufacturer's instructions. (See instruction tag attached to switch.)
- C. Prime the condensate receiver by filling one-half (1/2) full of water. **DO NOT RUN PUMPS DRY.** Mechanical seals will be damaged by running pumps dry. **DO NOT PRESSURIZE RECEIVERS.** Receiver has been tested for leaks at the factory.
- D. Prime the vacuum receiver by opening the isolation valve on the fresh water supply line. Turn the pump selector switches to the off position. With the selector switches in the off position, energize the power to the solenoid valve and float switch in the vacuum receiver. Allow receiver to fill until float is satisfied and solenoid closes. **DO NOT RUN PUMPS DRY.** Mechanical seals will be damaged by running pumps dry. **DO NOT PRESSURIZE RECEIVERS.** Receiver has been tested for leaks at the factory. Vacuum separation receiver is designed for atmospheric operation only. **DO NOT RESTRICT VENT.**
- E. Three Phase Units — Energize the power circuits and immediately check the direction of rotation of each condensate and vacuum pump. If unit is furnished with test push buttons, these should be utilized to momentarily check the direction of shaft rotation. Pump should rotate clockwise when viewed from motor end. If rotation is backward, interchange any two of the three power wires to the particular pump.
- F. Condensate Pumps — With the pumps running, adjust the throttling valve (closed) installed in pump discharge to bring pump discharge pressure to design conditions. When proper conditions have been met, tighten valve and remove handle.

NOTE: Bleed line shut-off valve *MUST* remain open unless pump is being serviced.

EQUALIZING LINE

A vacuum may be formed on the radiation side of the system when the steam stops flowing in the steam mains. This vacuum may be higher than the vacuum on the return side, causing condensate to hang up in the system. To correct this in an unzoned system, add equalizing line as shown. To correct this in a zoned system, install an equalizing line for each zoned section or install a vacuum breaker on the supply line on the radiation side of each zone valve.

TROUBLESHOOTING CHECKLIST VACUUM PRODUCER

PUMP WILL NOT START

1. Power supply has been interrupted. Disconnect switch is open or selector switch is improperly positioned.
2. Improper voltage supplied to motor. Check voltage and wiring with motor characteristics.
3. Incorrect starter coil for power supply.
4. Overload relays in starter have tripped out and must be reset. Ambient temperature may be excessive.
5. Wiring to power source is incorrect or connections may be loose.
6. Check pump controls for proper operation.
7. System has vacuum and vacuum switches are open.

PUMP RUNS CONTINUOUSLY

1. Pump is running backwards. Rotation should be clockwise looking down upon motor toward the pump. Rotation of 3 phase motors can be corrected by interchanging any 2 of the 3 wires. (Note: Any electrical service should be performed by a qualified electrician.)
2. System has leaks, preventing the unit from developing the design vacuum. The vacuum system must be tight.
3. The vacuum system is drawing a vacuum greater than the vapor pressure of the liquid, causing the liquid to boil and condense in the vacuum unit.
4. Holes in the nozzle plate are plugged and the system will not develop the proper vacuum. Inspect and clean the nozzle plates.

5. Incorrect liquid level in the hurling chamber (flooded or empty).
6. Improper settings on the vacuum switches or the selector switch is in the continuous position.

SYSTEM OVERFLOWS

1. System may be normal. Cooling water may be required to lower vapor pressure of the hurling water to be able to draw a deeper vacuum.
2. Temperature limit switch is set lower than required and adds unnecessary water.
3. The design vacuum is greater than the vapor pressure of the condensate within the system. The liquid is being boiled from the system and condensed in the hurling chamber.
4. Temperature limit switch is wired incorrectly.
5. Float switch may need adjustment.

SYSTEM STARTS AND STOPS RAPIDLY

1. Pumping against a small closed system. Add a vacuum storage tank or reset the vacuum switches.
2. Closed or partially closed valve in the air line.
3. Pipe friction losses in the suction line cause higher vacuum close to the vacuum producer. Relocate vacuum lines to a point which senses true system vacuum.

BOTH PUMPS RUN

1. Improper vacuum switch adjustment. Readjust the lead vacuum switch to make and break at deeper vacuums than the lag switch.

NOTE: Bleed line shut-off valve MUST remain open unless pump is being serviced.

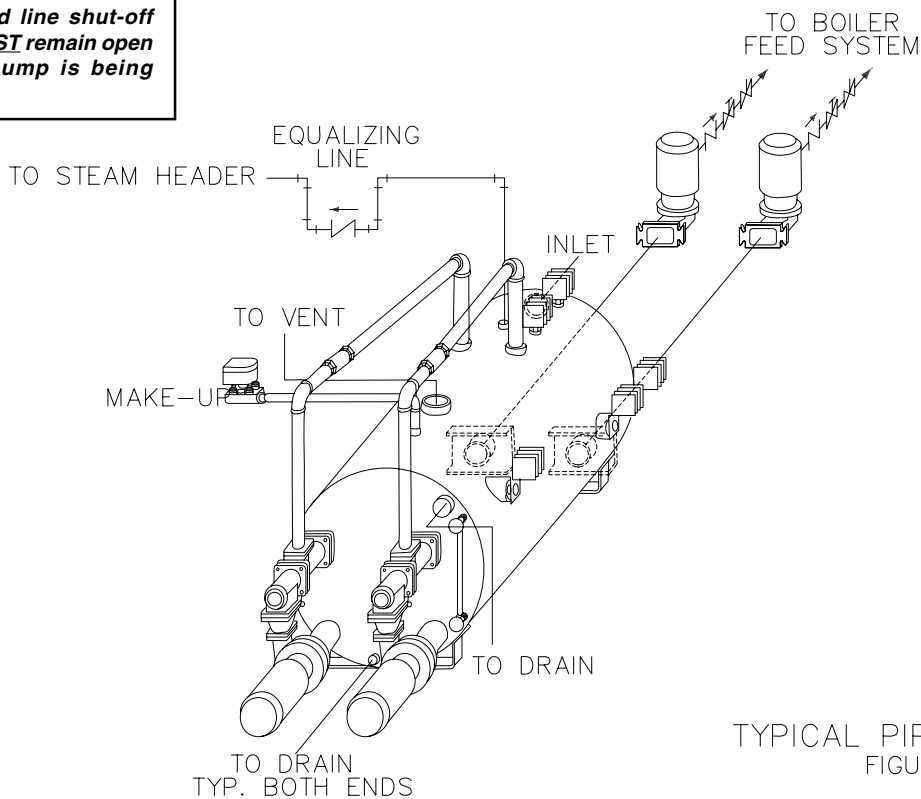

TYPICAL PIPING DIAGRAM
FIGURE 2

WARNING: The manufacturer will not be liable for any malfunction, damage, or destruction of the equipment if the equipment is not installed properly or is not installed by professionals, licensed and registered as required. Failure to follow and install the equipment according to job specific drawings, made by professionals who are licensed and registered as required and are familiar with the equipment, and failure to have the equipment installed by professionals, who are licensed and registered as required, in accordance with local, state, and federal codes will void all warranties and will void any liability upon the manufacturer. In addition, all warranties, including warranties of merchantability and fitness for a particular purpose are null and void for failure to follow job specific drawings made by professionals who are licensed and registered as required and are familiar with the equipment, and failure to have the equipment installed by professionals, who are licensed and registered as required, in accordance with local, state, and federal codes.

TROUBLESHOOTING CHECKLIST CONDENSATE PUMP

PUMP WILL NOT RUN

1. Power supply has been interrupted. Disconnect switch is open or selector switch improperly positioned.
2. Improper voltage supplied to motor. Check voltage and wiring with motor characteristics.
3. Incorrect starter coil for power supply.
4. Overload relays in starter have tripped out and must be reset. Ambient temperature may be excessive.
5. Wiring to power source is incorrect or connections may be loose.
6. Control signals are for pump to be "off."

GPM CAPACITY IS REDUCED

1. Pump is running backwards. Rotation should be clockwise looking down upon motor toward the pump. Rotation of 3 phase motors can be corrected by interchanging any 2 of the 3 wires. (Note: Any electrical service should be performed by a qualified electrician.)
2. Pump is **not throttled** to the design condition for the pump.
3. Total pressure at pump discharge is greater than that which the pump was designed for. Check pressure requirements which include system back pressure, and friction and static head.
4. Excessive suction lift, incorrect piping or undersized piping from the pump.
5. A valve in the pump suction line or discharge line is closed or throttled too much. Check valve in the pump discharge piping is installed backwards.
6. The impeller eye is blocked with trash or debris.
7. Pump is undersized for the system.

8. A strainer is dirty, causing a reduction in flow.
9. Pump has lost its prime. Release trapped air in the pump and reprime.
10. Steam traps are blowing through, causing the condensate to return at excessive temperatures. Depending on the unit and type of pump furnished, this could greatly reduce the capacity of the pump below its stated rating. Traps should be repaired or replaced.
11. Excessive temperatures. Capacity of pump may be reduced below its rating.

EXCESSIVE PUMP NOISE

1. Pump is running backwards. Check rotation by bumping the motor. Rotation should be clockwise while looking down at the rear of the motor.
2. Pump is working against a lower pressure than it was designed for. (The pump is not balanced or throttled.) Install a balancing valve, plug cock or steam cock in the discharge line following the gate valve. **Do not use a gate valve for balancing the pump. The seats in the valve will wear over time, causing the valve to lose its design condition point.** Throttle the balancing valve until the operating pressure at the pump discharge approaches the rated pump pressure.
3. Magnetic hum or bearing noise in motor. Consult the motor manufacturer's authorized service technician.
4. Starter chatters. Trouble is caused by low line voltage, poor connections, defective starter coil, or burned contacts.
5. Excessive ambient temperature. Correct the system conditions.
6. Entrained air. Release the trapped air pocket.

REPRESENTATIVE SERVICING

If trouble occurs that cannot be rectified, contact your local SHIPCO® representative. He will need the following information in order to give you assistance:

1. Complete nameplate data of pump and motor. SEE RATING NAMEPLATE.
2. Suction and discharge pipe pressure gauge readings.
3. Ampere draw of the motor.
4. A sketch of the pump hook-up and piping.

MODEL	_____	CONDENSATE PUMP
MANUFACTURED BY	P.O. BOX 279, SHIPPENSBURG, PA 17257	
SHIPCO PUMPS	PHONE: (717) 532-7321 • FAX: (717) 532-7704	
WWW.SHIPCOPUMPS.COM		
RATED	_____	GPM @ _____ PSIG
MOTOR HP	_____	VOLTAGE _____
UNIT SERIAL NO. _____		
— RECEIVER MUST BE VENTED —		

MECHANICAL SEAL REPLACEMENT INSTRUCTIONS FOR 56J FRAME MOTORS

Note: Seals will be damaged if operated Dry.

When it is necessary to replace a mechanical seal, refer to the following procedures:

- A. Close the isolation valves on the return line to the unit and discharge lines.
- B. Open power disconnect to unit. With power off, disconnect the motor power wiring and conduit from the motor.
- C. Remove the capscrews (4) fastening the pump head to the pump case.
- D. Separate the pump head from the case and lift the motor, pump head, and the impeller out of the pump case.
- E. Holding the top end of the motor shaft with a screwdriver or screwdriver socket, turn the impeller counterclockwise by inserting a flat tool between the vanes of the impeller.
- F. Remove the rotating portion of the mechanical seal from the end of the motor shaft.
- G. Remove the capscrews (4) fastening pump head to motor and remove the pump head.
- H. Remove the ceramic or stationary portion of the mechanical seal and cup rubber from the pump head.
- I. Install a new seal by thoroughly cleaning the machined recess in the pump head. Apply a thin coating of liquid detergent to the recess and outer edge of the new cup rubber. The new ceramic seal can then be pressed firmly into place **by hand**. Make sure the seal bottoms evenly. Should you be unable to bottom seal evenly, place a cardboard over the ceramic seal and force into place with a flat tool.
- J. With the motor in a vertical position (pump end up), install the pump head over the shaft and install capscrews (4).
- K. Clean the mating surfaces of the seal with a lint-free cloth. The carbon or rotating part should not be loose. Hold in place with a small amount of liquid detergent if necessary. Apply liquid detergent to the rubber lightly and install over the shaft with the carbon contacting the ceramic seal.
- L. Place the impeller on the shaft and tighten (clockwise rotation). (Install locking capscrew and washer - 3 phase only.)
- M. Reassemble by reversing procedures. Install a new head gasket between pump head and case.
- N. Reconnect power supply, open isolation valves, fill receiver one-half (1/2) full of water; pump is now ready for operation.

DO NOT RUN PUMP DRY.

- O. Pump may be tested for operation by hand operating float switch. Slight leakage may occur until seal surfaces adjust.

Check rotation — 3 phase only units pumps should rotate clockwise.

NOTE: Bleed line shut-off valve MUST remain open unless pump is being serviced.

FIGURE 3

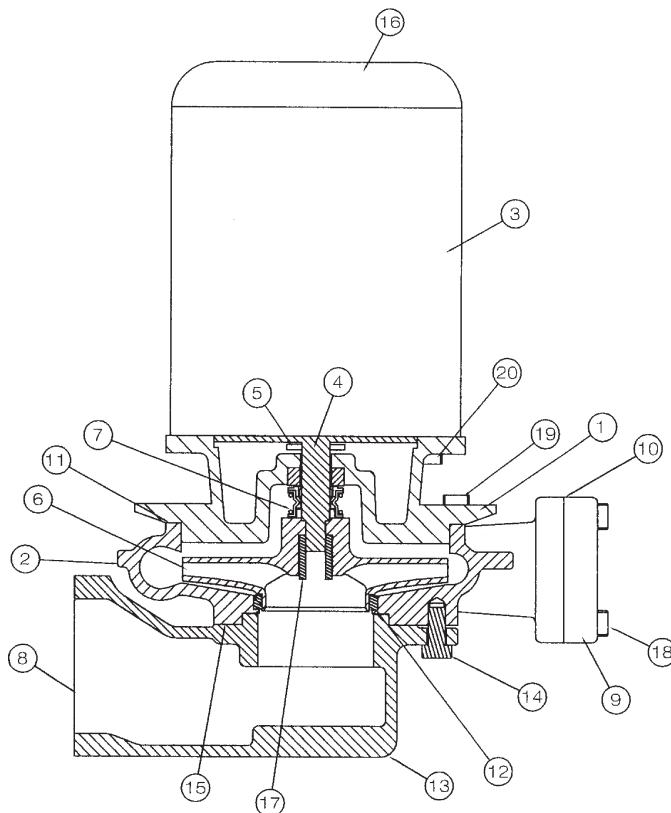

Model D • 56J Frame

1. Pump Head
2. Pump Case
3. Motor
4. Motor Shaft
5. Water Slinger
6. Impeller
7. Mechanical Seal
8. Pump Suction Gasket
9. Discharge Flange
10. Pump Discharge Gasket
11. Head Gasket
12. Wear Ring
13. Suction Housing
14. Capscrews (Suction Housing to Case)
15. Suction Housing Gasket
16. Drip Cover
17. Impeller Locking Nut
18. Capscrews
19. Capscrews
20. Capscrews

TO ORDER PARTS

— Refer to Figure 3 —
by Pump Model and Part Name

MECHANICAL SEAL REPLACEMENT INSTRUCTIONS FOR JM INTEGRAL FRAME MOTORS

Note: Seals will be damaged if operated Dry.

When it is necessary to replace a mechanical seal, refer to the following procedures:

- A. Close the isolation valves on the return line to the unit and discharge lines.
- B. Open power disconnect to unit. With power off, disconnect the motor power wiring and conduit from the motor.
- C. Remove the capscrews (4) fastening the pump head to the pump case.
- D. Separate the pump head from the case and lift the motor, pump head, and the impeller out of the pump case.
- E. Remove the locking capscrew and washer from the motor shaft.
- F. Using two thin flat pry bars opposite each other, pry between the head and impeller, being careful to pry only above vanes of the impeller so that the impeller shroud (or upper face) is not dented.
- G. Remove the rotating portion of the mechanical seal from the end of the motor shaft.
- H. Remove the capscrews (4) fastening pump head to motor and remove pump head.
- I. Remove the ceramic or stationary portion of the mechanical seal and cup rubber from the pump head.
- J. Install a new seal by thoroughly cleaning the machined recess in the pump head. Apply a thin coating of liquid detergent to the recess and outer edge of the new cup rubber. The new ceramic seal can then be pressed firmly into place **by hand**. Make sure the seal bottoms evenly. Should you be unable to bottom seal evenly, place a cardboard over the ceramic seal and force into place with a flat tool.
- K. With the motor in a vertical position (pump end up), install the pump head over the shaft and install capscrews (4).
- L. Clean the mating surfaces of the seal with a lint-free cloth. The carbon or rotating part should not be loose. Hold in place with a small amount of liquid detergent if necessary. Apply liquid detergent to the rubber lightly and install over the shaft with the carbon contacting the ceramic seal.
- M. Carefully start the impeller and key onto the motor shaft and push onto the shaft. If it is necessary to drive the impeller, hold the motor with the shaft up and use a steel spacer between the other end of the motor shaft and a solid bench. This is to prevent shock loads and damage to the motor bearings. Drive the impeller on with a wood dowel or large fiber punch in the center of the impeller eye, making sure it is going on straight and the key is going into place properly.
- N. Reinstall the locking capscrew and washer.
- O. Reassemble by reversing procedures. Install a new head gasket between pump head and case. Install a new gasket between the case and suction housing.
- P. Reconnect power supply, open isolation valves, fill receiver one-half (1/2) full of water; pump is now ready for operation.

DO NOT RUN PUMP DRY.

Q. Pump may be tested for operation by hand operating float switch. Slight leakage may occur until seal surfaces adjust.

Check rotation — 3 phase only units pumps should rotate clockwise.

NOTE: Bleed line shut-off valve MUST remain open unless pump is being serviced.

FIGURE 4

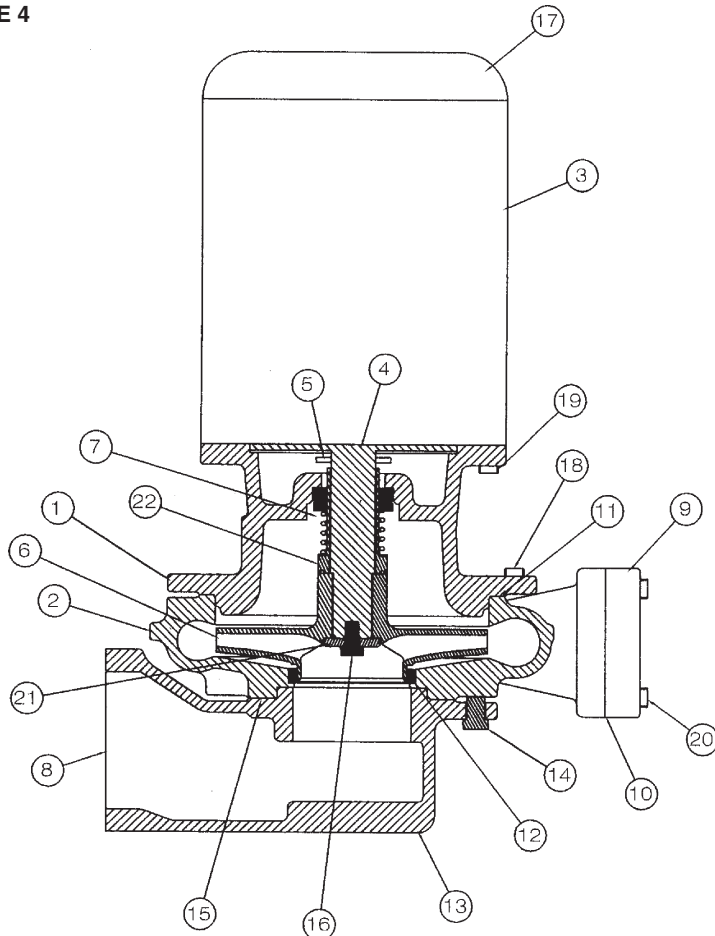

Model D • JM Frame

1. Pump Head
2. Pump Case
3. Motor
4. Motor Shaft
5. Water Slinger
6. Impeller
7. Mechanical Seal
8. Pump Suction Gasket
9. Discharge Flange
10. Pump Discharge Gasket
11. Head Gasket
12. Wear Ring
13. Suction Housing
14. Capscrews (Suction Housing to Case)
15. Suction Housing Gasket
16. Impeller Screw
17. Drip Cover
18. Capscrews
19. Capscrews
20. Capscrews
21. Impeller Washer
22. Shaft Sleeve (Mech. Seal)

TO ORDER PARTS

— Refer to Figure 4 —
by Pump Model and Part Name

TERMS AND CONDITIONS OF SALE

AGREEMENT

By entering your order or requesting a quote, you confirm that the following terms and conditions of sale are the legal agreement governing your purchase, and that no changes or additional or different terms will apply unless you have previously established a different written contract for these purchases with Shippensburg Pump Company, Inc., hereafter referred to as the Seller.

ORDER ACCEPTANCE

All orders are subject to acceptance by Seller at its general office in Shippensburg, Pennsylvania. Acceptance will be evidenced by Seller issuing its Sales Acknowledgement Form. The Sales Acknowledgement Form, together with any documents incorporated therein, shall constitute the entire agreement and may not be changed except in writing signed by Seller and Buyer. Publication and circulation of current price lists, catalogues and related literature by Seller shall not be deemed an offer to sell, but rather an invitation for offers to buy. Acceptance by Seller of the Buyer's order is expressly limited to the Terms and Conditions stated herein; any additional, inconsistent or different terms and conditions contained in the Buyer's purchase order or other documents supplied by Buyer are expressly rejected.

PAYMENT TERMS—PRICES

Payment terms are as follows: If the Buyer is a Credit Card Customer, the Buyer agrees to pay at the time of purchase the price, shipping and handling charges, taxes and duties quoted by the Seller. If the Buyer is an Account Holder, the Buyer agrees to pay invoices with payment terms of net thirty (30) days after date of invoice unless otherwise specifically agreed to in writing. If the Seller believes that the Buyer's financial condition requires it, the Seller reserves the right to require full or partial payment prior to manufacture or shipment. If the Buyer fails to make any payment when due, (1) the seller reserves the right to suspend performance and the Buyer agrees that any charges incurred prior to the suspension will be assessed to the Buyer and payable to the Seller; (2) the Buyer further agrees to pay a charge on the amount past due at the rate of 1½% per month (18% per year) or the maximum lawful rate, whichever is less. In the event of non-payment, the Buyer agrees to pay the Seller reasonable attorney's fees and court costs, if any incurred by the Seller to collect payment and interest charges. These terms shall apply to partial, as well as complete shipments of Product. Published prices are subject to change without notice and the right is reserved to invoice at prevailing prices at time of shipment unless otherwise specifically agreed to in writing. All quotations are conditional on 30 days acceptance unless stipulated otherwise in writing and to approved credit rating or reference, otherwise payment terms are cash with order or C.O.D.

DELIVERY—DELAYS

Shipping dates represent estimates only and are based on projected production schedules and commitments by suppliers. Seller shall not be liable for failure or delay in manufacturing or shipping Products, nor shall such failure or delay constitute grounds for cancellation if such failure or delay is directly or indirectly due to shortages of fuel or energy; acts of omissions of the Buyer; acts of God; war, riot, civil disturbances; labor difficulties; accident; inability to reasonably obtain materials; acts of transportation companies; or other causes of any kind whatever beyond the control of Seller. In the event of such delays, Seller reserves the right to make adjustments in price and delivery schedules.

FREIGHT TERMS

Prices are f.o.b. factory unless otherwise stated. Seller's responsibility ceases upon delivery to the transportation company at shipping point. It is the Buyer's responsibility to examine shipment upon arrival to ascertain if in good order. Any shortage or damage claims must be pursued by the Buyer. All weights shown on price sheets and literature are approximate. All packaging is standard domestic boxing, slat and wire crating and/or skidding. An additional charge will be made for full wooden crating or special packaging when specified on the order.

Seller will make every effort to consolidate orders and backorders wherever possible. Seller will not be responsible for excess charges due to their inability to consolidate shipments.

When requested by Buyer, shipments may be routed using premium carriers such as express or airfreight or the Buyer may specify the method or route of shipment. In such cases the shipment will be made on a "collect" basis and where applicable the freight allowance will appear as a separate line item on the product invoice, Seller reserves the right to select the transportation company where freight is allowed.

TAXES

In addition to the price stated, the amount of any present or future sales, use, excise or other similar tax applicable to the production, sale, use or transportation of the Products shall be paid by Buyer. In lieu of paying such taxes to Seller, Buyer may furnish Seller a Tax Exemption Certificate or Certificates acceptable to appropriate taxing authorities at any time prior to Seller's shipment of the Products.

CANCELLATIONS

Any order placed with Seller may be cancelled by the Buyer only upon payment of reasonable cancellation charges that shall include but not be limited to expenses already incurred, as well as material and labor commitments made by Seller.

SHIPMENT—TITLE—RISK OF LOSS

Shipment terms are f.o.b. Seller's facility, unless otherwise specifically agreed to in writing. Notwithstanding the granting of any allowances for shipping, title to and risk of loss for Products will pass to the Buyer when delivered to the Common carrier at the Seller's facility.

BACK CHARGES

All invoices shall be due and payable when submitted for payment in accordance with the provision entitled "Payment Terms—Prices." No withholding of funds, back charges, or credits against amounts otherwise due Seller will be permitted unless specifically agreed to in writing by Seller. Settlement of any amounts due Buyer will be negotiated as separate items and not as offsets against amounts otherwise due Seller from Buyer for Products sold hereunder.

RETURNED GOODS

Unused material of current manufacture can only be returned for credit with the written consent of Seller, under return goods policies existing at the date of the return. Products that are obsolete or made to special order are not returnable.

PATENT INDEMNITY

a. Patent Indemnity by Seller to Buyer

Seller agrees to indemnify and hold harmless the Buyer from and against all legal expenses which may be incurred, as well as all damages and costs (except all consequential and special damages and costs) which may be finally assessed against Buyer in any action for infringement of any United States Letters Patent by the Products delivered to Buyer hereunder; provided that the Buyer shall give Seller prompt written notice of any action, claim or threat of patent infringement suit, either oral or written, or of the commencement of any patent infringement suit against Buyer relating to Products sold by Seller hereunder; and provided Buyer shall give Seller opportunity to elect to take over, settle, or defend any such claim, action or suit through counsel of Seller's own choice and under

its sole direction, and at its sole expense, and provided that in the event Seller elects to take over, defend or settle same. Buyer will make available to Seller all defenses against any such claim, action, suit or proceeding known to or available to Buyer; and provided further that Seller shall have the right to substitute for any such Product or any part thereof claiming to infringe the patent right of others, non-infringing Products which will give equally good service. If the use of any such Product or any part thereof should be enjoined, Seller shall have the right at its own expense, to take any of the following courses of action:

- i. To procure for Buyer the right to continue using such Product;
- ii. To replace said Product with a non-infringing Product;
- iii. To modify the Product so that it becomes non-infringing; or
- iv. To remove said Product and refund the purchase price, transportation costs and installation costs thereof.

b. Limitation

The foregoing provisions as to patent protection by Seller to Buyer shall not apply to any of the following:

- i. To any Product manufactured to the design or specification furnished by the Buyer;
- ii. To orders for special non-commercial Products which Seller has not sold or offered for sale to the public on the open commercial market;
- iii. To any infringement occasioned by modification by Buyer of any Product without Seller's written consent, or any infringement arising from the use of a Product with any adjunct or device added by the Buyer without Seller's written permission.

c. Patent Indemnity by Buyer to Seller

To the extent that Products delivered hereunder are manufactured pursuant to detailed designs furnished by Buyer, Buyer agrees to indemnify Seller and hold Seller harmless from all legal expenses which may be incurred, as well as all damages and costs, which may finally be assessed against Seller in any action for infringement of any United States Letters Patent by such Products delivered hereunder. Seller agrees to promptly inform the Buyer of any claim for liability made against Seller with respect to such Products and Seller agrees to cooperate with the Buyer in every way reasonably available to facilitate the defense against any such claim.

GOVERNING LAW

The validity, interpretation and performance of any order shall be governed by the Uniform Commercial Code ("UCC") as adopted by the state in which the Products are manufactured by Seller.

WARRANTY AND LIMITATION OF LIABILITY

Seller warrants for a period of eighteen (18) months from date of shipment from its factory or one (1) year from date of installation, whichever occurs first, that all Products furnished by it are free from defects in materials and workmanship.

Seller's liability for any breach of this Warranty shall be limited solely to replacement or repair, at the sole option of Seller, of any part or parts found to be defective during the Warranty period providing the Product is properly installed and is being used as originally intended. Buyer must notify Seller of any breach of this Warranty within the aforementioned Warranty period; defective parts must be shipped by Buyer to Seller, transportation charges prepaid.

IT IS EXPRESSLY AGREED THAT THIS SHALL BE THE SOLE AND EXCLUSIVE REMEDY OF THE BUYER. UNDER NO CIRCUMSTANCES SHALL SELLER BE LIABLE FOR ANY COSTS, LOSS, EXPENSE, DAMAGES, SPECIAL DAMAGES, INCIDENTAL DAMAGES OR CONSEQUENTIAL DAMAGES ARISING DIRECTLY OR INDIRECTLY FROM THE DESIGN, MANUFACTURE, SALE, USE OR REPAIR OF THE PRODUCT WHETHER BASED UPON WARRANTY, CONTRACT, NEGLIGENCE OR STRICT LIABILITY. IN NO EVENT WILL LIABILITY EXCEED THE PURCHASE PRICE OF THE PRODUCT.

THE WARRANTY AND LIMITS OF LIABILITY CONTAINED HEREIN ARE IN LIEU OF ALL OTHER WARRANTIES AND LIABILITIES, EXPRESSED OR IMPLIED. ALL IMPLIED WARRANTIES OF MERCHANTABILITY AND FITNESS FOR A PARTICULAR PURPOSE ARE HEREBY DISCLAIMED BY SELLER AND EXCLUDED FROM THIS WARRANTY.

Seller neither assumes, nor authorizes any person to assume for it, any other Warranty obligation in connection with the sale of the Product. This Warranty shall not apply to any Product or parts of Products which (a) have been repaired or altered outside of Seller's facilities; or (b) have been modified or damaged through misuse, abuse, accident, neglect or mishandling by Purchaser or Purchaser's customer, erroneous voltage, modification, acts of God, or any other act not specifically stated; or (c) have been used in a manner contrary to Seller's instructions.

Products covered by this warranty are for the intended uses as described in the corresponding seller's instructions. Before using for any other application, user shall determine the suitability of the product for its intended use and user assumes all risk and liability in connection therewith.

No oral statement made by the seller, its agents, employees, or other representatives, concerning the product, its value, description, condition, design, specifications, performance, capability, durability, adaptability, or accuracy, shall be relied upon by the purchaser and is specifically and expressly excluded and invalidated as the basis for any bargain or warranty.

In the case of Products not manufactured by Seller, there is no Warranty from Seller, but Seller will extend to the Buyer any Warranty of Seller's supplier of such Products.

FORCE MAJEURE

Seller shall have no liability in respect of failure to deliver or perform, or delay in delivering or performing any obligations due to causes such as acts of omissions of Buyer; acts of God, fire, flood, war and civil disturbances; riot, acts of governments, currency restrictions, labor shortages or disputes, unavailability of materials, fuel, power, energy or transportation facilities, failures of suppliers or subcontractors to deliver on time and every other circumstance outside the reasonable control of Seller.

MODIFICATIONS

Unless otherwise provided, Seller reserves the right to modify the specifications of Products ordered by the Buyer providing that the modification will not materially affect the performance.

STORAGE CHARGE

If Buyer is unable to accept products in accordance with the applicable shipping schedule then Seller may arrange to store ordered Products and the cost of storage will be charged to Buyer.

ENTIRE CONTRACT

These provisions constitute all the terms and conditions agreed upon by the parties and shall replace and supersede any provisions on the face and reverse side of Purchase Order and any attachment thereto, or any prior general agreement inconsistent with the provisions hereof except that orders by Representatives with whom Seller has an Agreement shall be subject to the provisions of the Agreement. No modification hereof shall be valid unless in writing and duly signed by a person authorized by Seller. The provisions hereof shall not be modified by any usage of trade, or any course of prior dealings or acquiescence in any course of performance.