

- ⊗ GATE VALVE
- ⊘ CHECK VALVE
- ⊗ STEAM, PLUG COCK, THROTTLING OR BALANCING VALVE
- ⊕ UNION
- ⊗ AUTOMATIC FLOW VALVE
- ⊖ ORIFICED BYPASS NIPPLE
- ▷ CONCENTRIC REDUCER

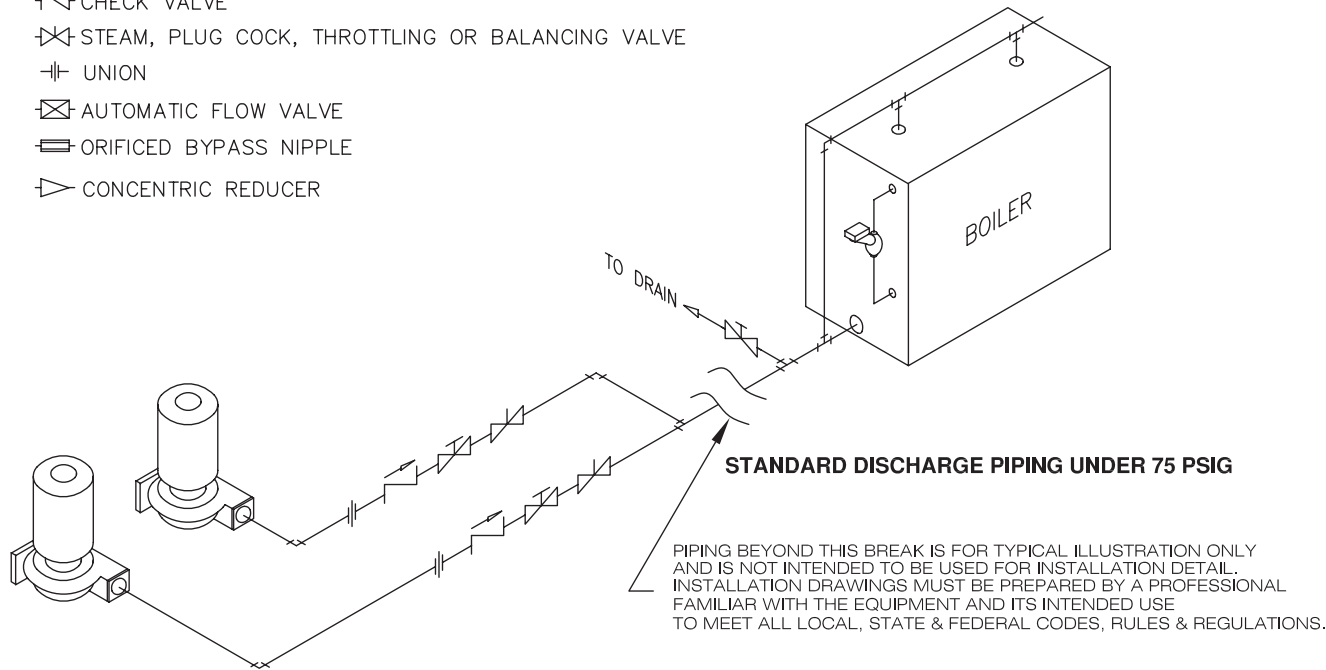

DISCHARGE PIPING W/ AUTOMATIC FLOW VALVE

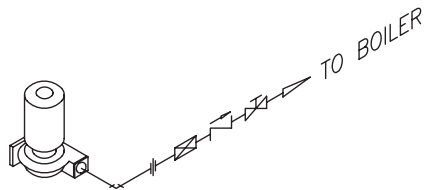

If centrifugal feed pump is operating at 75 PSIG or greater a Automatic Flow Valve typically is utilized.

DISCHARGE PIPING W/ AUTOMATIC FLOW VALVE & BYPASS

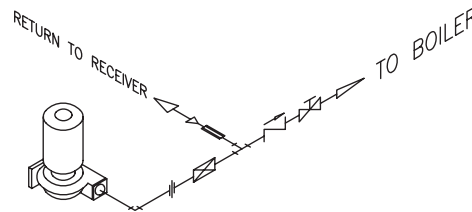

If continuous running centrifugal feed pump on Deaerator and horsepower of motor is 7 1/2 Hp and larger a Bypass line with Orifice must be utilized.

**1 BOILER, 2 PUMPS—AUTOMATIC
STANDBY—AUTOMATIC ALTERNATION**

**SUGGESTED CONTROL SPECIFICATIONS
(To be added to Boiler Feed Unit Specification)**

The unit manufacturer shall furnish, mount on the pump unit, and wire a NEMA 2 control cabinet with piano hinged door, enclosing the following:

- 2 Combination magnetic starters (having 3 overload relays) with circuit breakers and cover interlocks.
- 2 "Auto-Off" selector switches.
- 2 Pump running pilot lights.
- 1 Electrical alternator.
- 1 Control Circuit disconnect switch with cover interlock.
- 1 Numbered terminal block.
- 1 Fused control circuit transformer when the motor voltage exceeds 130 volts.
- 2 Momentary contact "test" push buttons.

Control cabinet shall contain U.L. listed or recognized components. Control cabinet shall be listed and labeled by Underwriter's Laboratory.

Control components shall be provided by the unit manufacturer for operation as follows: as the level in the boiler recedes, the upper switch on the pump control will close, starting the lead pump. As the level is restored, the switch will open, and stop the pump. Should the level continue to recede, the lower switch will close, starting the lag pump.

The electrical alternator will provide for automatic transfer of operating sequence after each cycle. The alternator will also provide for simultaneous operation of both pumps under peak load conditions and operation of the standby or lag pump if the lead pump or its control fails.

The installing contractor, in addition to the pump control(s), shall provide and install all low water burner cut-off switches, all low water alarms and all associated circuits in accordance with all local codes.

The unit shall be factory tested as a complete unit and a certified test report of pump characteristics produced, which shall be submitted prior to shipment. The unit manufacturer shall furnish complete elementary and connection wiring diagrams, piping diagrams, and installation and operation instructions.

Manufacturer shall be Shippensburg Pump Company, Inc., Shippensburg, PA

Rev. 1/06

**DRAWING FOR REFERENCE USE ONLY
REFER TO ORDER FORM TO CONFIRM
ITEMS SUPPLIED BY MANUFACTURER**

**SHIPCO®
PUMPS**

MANUFACTURED BY
SHIPPENSBURG PUMP COMPANY INC.
P.O. Box 279 Shippensburg, Pa. 17257
PHONE 717 532-7321 / FAX 717 532-7704
WWW.SHIPCOPUMPS.COM

SHIPCO® IS A REGISTERED TRADEMARK OF SHIPPENSBURG PUMP CO., INC.

Ref: Boiler piping ASME Section 1 by others.
Suggested boiler feed piping to be installed in accordance with applicable Federal, State and Local codes.

CENTRIFUGAL PUMP
TWO PUMPS FEEDING ONE BOILER
WITH AUTO STANDBY

DRAWN BY	DATE	REVISION
S.A.D.	6-7-04	

Piping Diagram No. 61B2P-NAA